Breakage susceptibility studies on alfalfa and animal feed pellets

T.B. LARSEN, S. SOKHANSANJ, R.T. PATIL and W.J. CRERAR

Department of Agricultural and Bioresource Engineering, University of Saskatchewan, Saskatoon, SK Canada S7N 5A9. Received 3 October 1994; accepted 3 January 1996.

Larsen, T.B., Sokhansanj, S., Patil, R.T. and Crerar, W.J. 1996. **Breakage susceptibility studies on alfalfa and animal feed pellets.** *Can. Agric. Eng.* 38:021-024. Pellet durability index, expressed as percent, is a measure of pellets resistance to breakage. Industrial experience has shown that the ASAE S269.4 tumbler cannot indicate the true durability of pellets. A new pellet durability tester (DURAL) which subjects pellets to impact and shear forces was developed. The new tester was evaluated for its consistency in measuring durability of feed pellets and the results were compared to the ASAE Standard S269.4. Statistical analysis of the data showed that the new pellet durability tester was capable of discriminating the durability of alfalfa and feed grain pellets.

L'indice de durabilité des granules, exprimé en pourcentage, est une mesure de la résistance des granules au bris. Des expériences en milieu industriel ont démontré que le tambour rotatif décrit dans la norme ASAE S269.4 n'indique pas la vraie durabilité des granules. Un nouvel appareil d'essai (DURAL), qui mesure la durabilité des granules en les soumettant à des forces de cisaillement et d'impact, a été développé. On a évalué l'uniformité des mesures de durabilité des granules du nouvel appareil et les résultats ont été comparés à ceux de la norme S269.4. L'analyse statistique des données a montré que le nouvel appareil d'essai permettait de faire la distinction entre la durabilité des granules de luzerne et des granules de moulée.

INTRODUCTION

Animal feed pellets are produced by a series of unit operations such as drying, mixing, grinding, conditioning, extruding, and cooling. The main components of feed pellets are either alfalfa or feed grains. Freshly harvested alfalfa is used to make "dehy pellets" whereas field-dried alfalfa is used to make "sun-cured pellets." Dehy pellets have a higher protein content (18-20%) than the sun-cured pellets (14-16%). The composition of feed grain pellets is based on the desired protein, carbohydrates, and fiber levels. Materials used in the formulation of feed grain pellets are selected by feeding value and market price.

Testing durability of pellets is important for industry to evaluate pellet quality and eventually to minimize losses during handling and transportation. It has been reported that 20-30% losses in the form of fines are found in bulk products at the user level (Hill and Pulkinen 1988). Fasina and Sokhansanj (1996) reported that 4-5% pellet breakage occurs each time alfalfa pellets were dropped into storage bins or holding containers at port.

Controlling product quality has always been an important issue for manufacturers of alfalfa and feed grain pellets. Traditionally product quality control has been site specific; however, industry has established off-site testing facilities

for comparing product quality of individual plants. To ensure effectiveness of off-site testing, the procedure to measure durability must be capable of distinguishing between good and poor pellets as well as allowing many samples to be tested daily.

The ASAE Standard S269.4 (ASAE 1992) specifies a procedure for testing the durability of feed pellets which involves tumbling 500 g of pellets in an enclosure rotating at 50 rpm for 10 minutes. The tumbled sample is sieved on a wire mesh sieve of a specified size depending on the pellet diameter. The durability of the sample is calculated from the ratio of the mass of pellets remaining on the sieve after tumbling to the mass of pellets on the sieve before tumbling. The test is conducted after the pellets have been cooled.

Alfalfa pellets are harder and more durable than most other feed pellets. Industrial experience has shown the ASAE S269.4 test is not suitable for determining pellet durability as it cannot distinguish between grades of alfalfa pellets; these pellets are too hard. Therefore industry has attempted to develop devices to determine the durability of alfalfa pellets. One group of Canadian plants uses a device that consists of two leather pouches affixed to a rotating wheel. The alfalfa pellets are placed into the leather pouches and subjected to impact forces against metallic protrusions as the pouches rotate in a cylindrical housing. This device is not a good method for measuring durability of pellets since it does not provide uniform breakage within the entire sample.

The Stein breakage tester (Stein Laboratories, Atchison, KS) has been used to measure the breakage susceptibility of corn kernels (McGinty 1970), soybeans (Paulsen et al. 1981), and lentils (Tang et al. 1991). The Stein breakage tester also has been used for testing the breakage of grains. Sokhansanj et al. (1991) compared the Stein breakage tester to the ASAE Standard S269.4 for determining the durability of small diameter alfalfa pellets. The Stein breakage tester provided a better ability to discriminate between pellet types than the ASAE Standard S269.4. However, the Stein breakage tester is not suited for handling the diverse needs of the alfalfa and feed grain industry. Therefore, a new tester, called DURAL, for determining the durability of alfalfa pellets was developed. The tester was compared to the performance of the Stein breakage tester for alfalfa pellets (Larsen et al. 1993).

OBJECTIVES

The present investigation is aimed at further testing the DURAL tester using alfalfa and feed grain pellets. The de-

tailed objectives are (1) to develop time and speed versus pellet durability relationships for the DURAL tester for alfalfa and feed grain pellets; and (2) to compare the DURAL tester with the ASAE Standard S269.4 tumbler for its ability to discriminate between feed pellet samples.

MATERIAL AND METHODS

Five types of commercially produced alfalfa pellets: 6.4 mm dehy, 6.4 mm sun-cured, 7.9 mm sun-cured, 9.5 mm dehy, and 12.7 mm sun-cured and seven different compositions of feed grain pellets each 4.4 mm in diameter were used. Tests were conducted in five replications for the ASAE Standard S269.4 and DURAL test procedures.

Durability tests

Figure 1 shows a photograph of the DURAL tester that consists of a motor, stand, control panel, sample canister, and rotating impeller. The impeller is comprised of four 3.5 mm x 5.5 mm blades placed at 45° on a hub that rotates inside a 155 mm diameter by 150 mm deep canister. Detailed schematic of the DURAL is given in Fig. 2. The ASAE S269.4 tumbler is a box of 300 mm x 300 mm x 125 mm with a 230 mm long baffle centered diagonally inside the box. A 500 g pellet sample is loaded into the box and tumbled at 50 rpm for 10 minutes.

Standard S269.4 specifies that pellet samples must be screened before and after tumbling. The sieving is done by hand on a wire mesh sieve one size smaller than the nominal

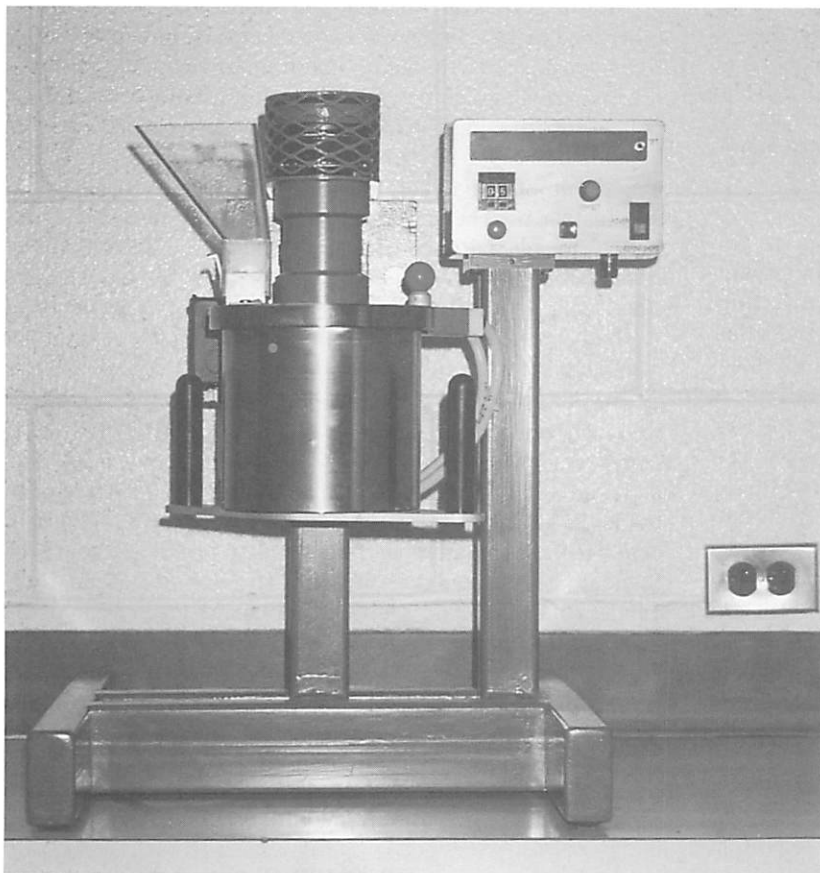

Fig. 1. A photograph of the DURAL pellet durability testing apparatus.

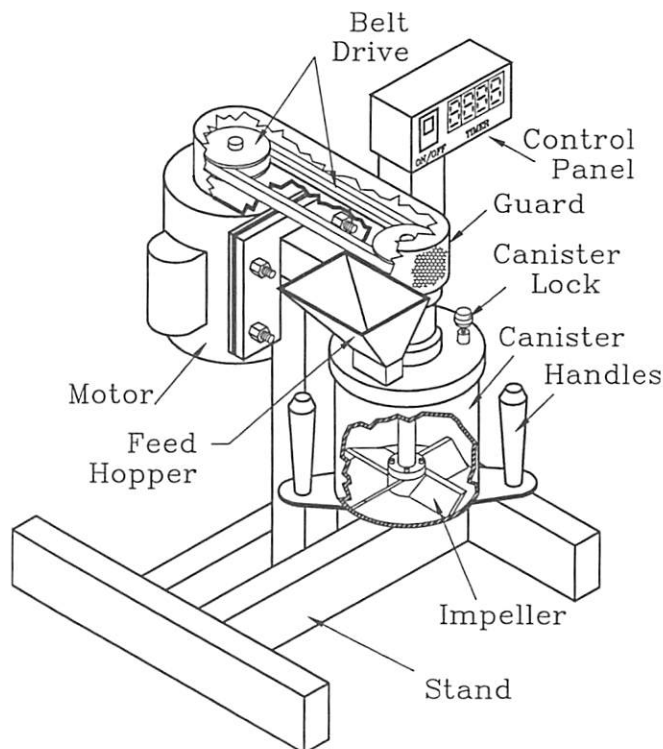

Fig. 2. Schematic diagram of the DURAL pellet durability tester.

diameter of the pellets. The sieve sizes used in this experiment were: 3.6 mm sieve for 4.8 mm pellets, 5.7 mm for 6.4 mm pellets, 6.35 mm for 7.9 mm pellets, 8 mm for 9.5 mm pellets, and 9.51 mm for 12.7 mm pellets.

To prepare for the DURAL test, a sample was cleaned by sieving on a 5.95 mm round hole sieve for all sizes of alfalfa pellets and a 3.6 mm round hole sieve for feed pellets. A cleaned sample of approximately 100 g was weighed and placed in the chamber of the DURAL tester. The tester was analyzed for its effect of impeller speed and sample residence time on pellet durability by using impeller speeds of 1600 rpm and 800 rpm for 30, 60, 90, and 120 s. The tester was then operated at 1600 rpm for 30 s for all the durability tests on alfalfa and grain pellets. The contents of the chamber were manually sieved by shaking the sieve 30 times. The durability was calculated from the ratio of the mass left on the sieve to the original mass.

Data analysis

A statistical analysis was performed using the SAS statistical package (SAS 1986) to evaluate and compare the DURAL tester to the ASAE Standard S269.4. An analysis of variance was conducted on all data sets using PROC GLM. The ANOVA F test was used to indicate if the variance between means of the samples was significantly different from the variance within

the samples. However, the F value could not be used to indicate which means of the samples were significantly different. Therefore further analysis of variance to compare the significant difference between individual means was conducted at 95% probability level using the least significant difference method (LSD) within PROC GLM.

RESULTS AND DISCUSSION

Table I shows the effect of retention time and impeller speed on pellet durability for the DURAL tester. The durability was lower at higher speeds and at longer residence times. This experiment was conducted to find the optimum combination of speed and time to represent the realistic value of the pellet durability as experienced in actual handling practices. The alfalfa pellets break to about 30% by the time they reach the export destination (Hill and Pulkinen 1988). Similarly the breakage of feed pellets in transport is much higher than the values obtained by the ASAE tumbler method. To represent the realistic value, the targeted value of pellet durability was at 80% for average quality alfalfa pellets and based on this, the optimum combination of time and speed was determined for the DURAL tester. The time required for testing is a major cost concern in the industry. To minimize the cost of testing, the best evaluation of pellet durability by the DURAL tester was provided by operating at 1600 rpm for 30 seconds. The DURAL tester provided uniform breakage for both pellet types at this set point. Two sieve sizes were chosen, one for the alfalfa and one for the feed grain pellets because of the large difference between pellet sizes. The small sieve size used for feed grain pellets cannot be used for alfalfa pellets because larger broken pieces would be separated out from the whole pellets.

Table II lists the results of the durability tests conducted on alfalfa pellets. The ASAE S269.4 durabilities for alfalfa pellets fall in the range of 98.6% to 96.1% whereas the corresponding durability using the DURAL tester is 91.0% to 64.3%. Analysis of variance for alfalfa pellets produced an F value for the ASAE S269.4 tumbler of 52.6 and 342.3 for the DURAL tester. These two values are larger than the null hypothesis F value of 2.32 (at 0.05 significance level). This shows that the discriminating ability of the DURAL was significantly higher than the ASAE method. LSD analysis results also are given in Table II. Alfalfa pellets tested by the DURAL tester were all significantly different at $p=0.05$, but the ASAE S269.4 tester could not differentiate between pellet samples.

Results from the grain pellet durability tests are given in Table III. The range for the DURAL tester is 73.3% to 5.6% whereas the ASAE S269.4 tumbler ranged from 96.5% to 89.5%. The large range of pellet breakage in the DURAL tester was a more realistic range for feed pellets. The softest pellets at 5.6% were high nutrient diet (HND) for a sow ration which contains poor binding materials

Table I: Effect of time and impeller speed on pellet durability (%) for alfalfa and feed grain pellets

Pellet type	Speed (rpm)	Time (min)			
		0.5	1.0	1.5	2.0
Alfalfa	800	96.8	93.8	91.8	88.5
	1600	70.2	42.0	21.4	10.6
Feed grain	800	95.1	91.9	89.3	87.4
	1600	74.4	45.6	39.7	26.3

compared to 73.3% for a heifer ration pellet. The ASAE S269.4 tester gave the durability of HND pellets to be 89.5%. The coefficient of variation in the DURAL tester was higher than the ASAE S269.4 procedure. This was mainly due to the higher degree of pellet breakage in the DURAL tester. Analysis of variance and F statistics showed that in the case of feed pellets the DURAL was highly significant compared to the ASAE standard in discriminating among grades of pellets. The least significant different test for grain pellets, shown in Table III, rated the majority of the feed pellets not significantly different when tested using the ASAE S269.4 procedure.

Table II: Results of pellet durability using DURAL and the ASAE S269.4 tumbler for alfalfa pellets

Pellet type	ASAE S269.4 tester Durability (%)			DURAL tester Durability (%)		
	Mean ¹	S. D. ²	LSD ³	Mean ¹	S. D. ²	LSD ³
6.4 mm Sun-cured #2	98.6	0.2	A	91.0	0.5	A
6.4 mm Dehy #2	97.8	0.3	B	88.7	0.7	B
7.9 mm Sun-cured #2	97.4	0.2	C	86.6	0.6	C
6.4 mm Sun-cured #1	97.5	0.2	C	84.7	0.6	D
9.5 mm Dehy	96.3	0.5	D	83.3	1.7	E
12.7 mm Sun-cured	96.4	0.3	D	81.4	0.8	F
6.4 mm Dehy #1	97.5	0.2	C	71.1	0.6	G
7.9 mm Sun-cured #1	96.1	0.2	D	64.3	2.0	H

¹ Mean of 5 replications

² SD is standard deviation.

³ LSD is the least significant difference ranking for pellet type based on pellet durability. Means with the same letter are not significantly different from each other at $p=0.05$.

Table III: Results of pellet durability using DURAL and the ASAE S269.4 tumbler for feed grain pellets

Pellet type	ASAE S269.4 tester Durability (%)			DURAL tester Durability (%)		
	Mean ¹	S. D. ²	LSD ³	Mean ¹	S. D. ²	LSD ³
27% Solulac pellet	96.4	0.4	A	73.3	1.0	A
16% Drylow II	96.5	0.1	A	71.5	0.6	B
21% mix pellet	96.3	0.3	A	65.7	2.3	C
35% dairy supplement	96.4	0.1	A	65.0	0.5	C
24% heifer pellet	94.6	0.1	B	59.5	0.8	D
Turkey grower	93.2	0.2	C	25.8	1.3	E
Sow ration (HND)	89.5	0.2	D	5.6	0.2	F

¹ Mean of 5 replications

² SD is standard deviation

³ LSD is the least significant difference ranking for pellet type based on pellet durability. Means with the same letter are not significantly different from each other at p=0.05.

CONCLUSIONS

The following conclusions can be drawn from this study.

- 1) The DURAL tester discriminated between pellet durability means better than the ASAE S269.4 tumbler.
- 2) The DURAL tester produced a wider range of breakage on pellets of varying degrees of hardness.
- 3) The DURAL tester processed pellet samples in 30 s as compared to 10 min for the ASAE S269.4 tumbler.

ACKNOWLEDGMENT

This research was supported by the Natural Sciences and Engineering Research Council of Canada through a Strategic Research Grant and by Saskatchewan Agriculture and Food through a Strategic Research Program. We acknowledge the assistance of the Canadian Dehydrators Association, particularly Dale Pulkinen of KAPT-AL Services for his technical advice, Al Blais of Federated Cooperatives Limited in Saskatoon for providing grain feed samples, and the assistance of engineering students Duane Sholter and Jubin Nakhai.

REFERENCES

ASAE. 1992. Standard S269.4 - Cubes, pellets, and crumbles-definitions and methods for determining density, durability, and moisture content. In *ASAE Standards 1992*, 384-386. St. Joseph, MI: ASAE.

Fasina, O.O. and S. Sokhansanj. 1996. Effect of fines on storage and handling properties of alfalfa pellets. *Canadian Agricultural Engineering* 38(1):25-29.

Hill B. and D.A. Pulkinen. 1988. A study of factors affecting pellet durability and pelleting efficiency in production of dehydrated alfalfa pellets. Saskatchewan Dehydrators Association, Saskatoon, SK.

Larsen, T.B., R.T. Patil and S. Sokhansanj. 1993. Performance evaluation of a new durability tester for alfalfa and feed pellets. ASAE Paper No. RRV-305. St. Joseph, MI: ASAE.

McGinty, R.J. 1970. Development of a standard grain breakage test. U.S. Agricultural Research Services Progress Report 51-34. U.S. Department of Agriculture, Washington, DC.

Paulsen, M.R., W.R. Nave and L.D. Gray. 1981. Soybean seed quality as affected by impact damage. *Transactions of the ASAE* 24:1577-1582.

SAS. 1986. SAS User's Guide: Statistics. Version 5. Cary, NC: SAS Institute Inc.

Sokhansanj, S., R.T. Patil, G. Ahmadnia, O.O. Fasina and J. Irudayaraj. 1991. Procedures for evaluating durability and density of forage cubes and pellets. CSAE Paper No. 91-402. Saskatoon, SK: CSAE.

Tang, J., S. Sokhansanj, F.W. Sosulski and A.E. Slinkard. 1991. Lentils quality- Effects of artificial drying and six-month storage. *Canadian Institute of Food Science and Technology Journal* 24(5): 283-286.