

---

# Distribution of introduced carbon dioxide through stored wheat bulks - a pilot scale study

K. ALAGUSUNDARAM<sup>1</sup>, D.S. JAYAS<sup>1</sup>, W.E. MUIR<sup>1</sup>, N.D.G. WHITE<sup>2</sup> and R.N. SINHA<sup>2</sup>

<sup>1</sup>Department of Biosystems Engineering, 438 Engineering Building, University of Manitoba, Winnipeg, MB, Canada R3T 5V6; and <sup>2</sup>Agriculture and Agri-Food Canada, Winnipeg Research Centre, 195 Dafoe Road, Winnipeg, MB, Canada R3T 2M9. Received 28 March 1994; accepted 19 January 1996.

---

Alagusundaram, K., Jayas, D.S., Muir, W.E., White, N.D.G. and Sinha, R.N. 1996. **Distribution of introduced carbon dioxide through stored wheat bulks - a pilot scale study.** *Can. Agric. Eng.* 38:083-089. The distribution of introduced carbon dioxide (CO<sub>2</sub>) was measured experimentally in three 1.42-m-diameter bins containing wheat to a depth of 1.37 m. Dry ice was used as a source of CO<sub>2</sub> gas. The effects on the distribution of CO<sub>2</sub> of the floor opening (circular near the centre, rectangular, and circular near the wall), the grain surface left open or covered with a polyvinylidene chloride (PVDC) sheet, and the mass of introduced dry ice were studied. The CO<sub>2</sub> gas moved more rapidly in the horizontal direction than in the upward vertical direction. Although there were gradients in the vertical direction, the CO<sub>2</sub> concentrations were nearly uniform in the horizontal direction in the top two-thirds of the wheat bulks. The efficiency of retention (the ratio of the mass of CO<sub>2</sub> retained in a bin to the total mass of CO<sub>2</sub> input,  $\eta_r$ ) was, on average, 6 percentage points greater when the grain surfaces were covered with the PVDC sheet than when grain surfaces were open. The maximum observed  $\eta_r$  was only 55%. **Keywords:** carbon dioxide distribution, controlled atmosphere, modified atmosphere

La distribution du gaz carbonique (CO<sub>2</sub>) introduit a été mesurée dans trois compartiments expérimentaux de 1.42 m de diamètre et contenant du blé sur 1.37 m de profondeur. De la glace sèche a été utilisée comme source de CO<sub>2</sub>. Les impacts des ouvertures des planchers, de la surface de la masse de blé à l'air libre ou recouverte d'une pellicule de chlorure de polyvinylidene (PVDC) ainsi que la masse de glace sèche introduite, sur la distribution du CO<sub>2</sub> ont été étudiés. Le mouvement du CO<sub>2</sub> s'est fait plus rapidement dans l'axe horizontal que vertical. Quoiqu'il y ait eu un gradient dans la direction verticale, les concentrations de CO<sub>2</sub> dans l'axe horizontal étaient uniformes dans les deux premiers tiers de la masse de blé. L'efficacité de rétention (le rapport entre la masse de CO<sub>2</sub> retenue dans le compartiment et la masse totale de CO<sub>2</sub> introduit,  $\eta_r$ ) a été de 6% plus élevée pour les grains recouverts de PVDC. La valeur maximale de  $\eta_r$  observée a été de 55%.

## INTRODUCTION

Traditionally, chemicals such as contact insecticides, acaricides, and fumigants have been used to control stored-product pests (Freeman 1973). These chemicals leave objectionable residues in the grain and are hazardous to handle and apply. Furthermore, several species of stored-product pests have developed resistance to chemicals (White and Loschiavo 1985; Champ 1986). Controlled atmosphere (CA) storage is a pesticide-free method of insect control (Banks and Annis 1977). In a CA

storage, CO<sub>2</sub> or N<sub>2</sub> gases are injected into the grain bulk to create lethal concentrations of high-CO<sub>2</sub> or low-O<sub>2</sub> atmospheres, respectively. The success of a CA treatment of grains depends on the uniformity of distribution of the introduced gases as well as the maintenance of these gases in the store until all the insects are killed.

Numerous research studies, both in the laboratory and in the field, have been conducted to determine the effectiveness of controlled atmospheres in controlling stored-product pests and were reviewed by Jayas et al. (1991). Although studies in large bulks of grain provide useful results, these data are often empirical in nature and cannot be generalized. Experimentally determining distribution of CA gases in various storage structures containing different grains is labour intensive and prohibitively expensive. On the other hand, the distribution and maintenance of CA gases in grain bulks can be studied using mathematical models. The usefulness of the mathematical models can be improved greatly if they are validated against experimental data under controlled conditions. The data from field studies can be used for validation, but because of many uncontrollable factors they are usually difficult to interpret and at times, because of the high labour requirement, measurements are usually taken at limited points in the bulk. Pilot-scale tests can be used more effectively for the validation of the mathematical models because each of the variables affecting the process can be studied independently. The variables that affect the movement of CO<sub>2</sub> in grain bulks are: gas transport mechanisms (such as diffusion and convection), gas loss because of leaks in the storage structure, weather changes, and foreign material content and distribution.

Only a few research studies have been conducted to determine the retention of CA gases in small containers (Navarro et al. 1981, 1986; White et al. 1990; White and Jayas 1992). In all the previous studies, usually the average CO<sub>2</sub> concentrations or the CO<sub>2</sub> concentrations along the height of the grain bulk were reported and the distribution of CO<sub>2</sub> gas in the horizontal direction was not studied.

The objective of this study was to determine the distribution of CO<sub>2</sub> gas through wheat bulks contained in bins of 1.42-m-diameter by 1.47-m-tall that were equipped with three different partially-perforated floors (circular near the centre, rectangular, and circular near the wall). The data

obtained were used to validate a model of CO<sub>2</sub> movement through stored wheat (Alagusundaram et al. 1996).

## MATERIALS AND METHODS

### Test bins

Three 1.42 m diameter by 1.47 m tall bins were obtained from a local manufacturer (Westeel, Winnipeg, MB). Each bin was made by welding two plain galvanized-steel sheets along the height and rolling these to form 1.42 m diameter cylinders. Two such cylinders were bolted together to give 1.47 m tall bins. Each bin was equipped with a partially perforated floor (Bin 1: circular near the centre, Bin 2: rectangular, and Bin 3: circular near the wall) (Fig. 1). Metal boxes 0.5 x 0.5 x 0.37 m for Bins 1 and 3 and 1.22 x 0.46 x 0.36 m for Bin 2 were fabricated using 0.9-mm-thick sheet metal and mounted centrally under the floor openings of the bins. Known quantities of dry ice pellets were placed in these boxes to create CO<sub>2</sub> gas. The boxes were equipped with a 75 mm diameter PVC pipe fitting and a screw cap for placing the dry ice and for aerating the grain after each replication. The bins were placed on 0.5 m high wooden platforms. All the joints and bolt holes in the bins were sealed using silicon sealant.

Semirigid nylon tubes of 3.2 mm outside diameter were installed at five levels, spaced 0.33 m apart in the vertical direction to draw gas samples. There were 11, 13, and 12 sampling points at each level (levels were numbered from 1 at the bottom to 5 at the top) for Bins 1, 2, and 3, respectively (Fig. 1). The gas and temperature sampling points in each bin were fixed depending on the size and location of floor opening and to draw as many samples as possible to completely determine the CO<sub>2</sub> distribution in the wheat bulk. The gas sampling tubes were terminated with 6.4 mm diameter copper nipples soldered to the bin wall at each radius and at each level. The outsides of the nipples were fitted with rubber septa.

In addition to gas samples, grain temperatures were also recorded. The grain temperatures were recorded to check for the uniformity of temperature and to account for the changes in the diffusion coefficients with temperature in the model predictions. To monitor the grain temperatures, copper-constantan (type T) thermocouples were installed at five locations along the central axis of Bin 1 and at 15 locations in each of Bins 2 and 3 (Fig. 1). The thermocouples were connected through a multichannel switch to a temperature indicator.

### Experimental procedure

The bins were filled with Canadian hard red spring wheat (cv. 'Katepwa'), graded No. 1 by the Canadian Grain Commission. The wheat had 0.5% dockage and 12.8% moisture content (wet basis). The bins were filled to a depth of 1.37 m by manually pouring the wheat from buckets. For Bins 1 and 3, 180 g of dry ice, which with perfect purging and mixing would create an average CO<sub>2</sub> concentration of approximately 10% by volume in the intergranular air space of the wheat bulk, was placed in the boxes, for Bin 2, 370 g of dry ice was used. Three replicates with 180 g dry ice were conducted by emptying and refilling the Bin 1 each time. In this experiment the bin was emptied and refilled each time to check if refilling

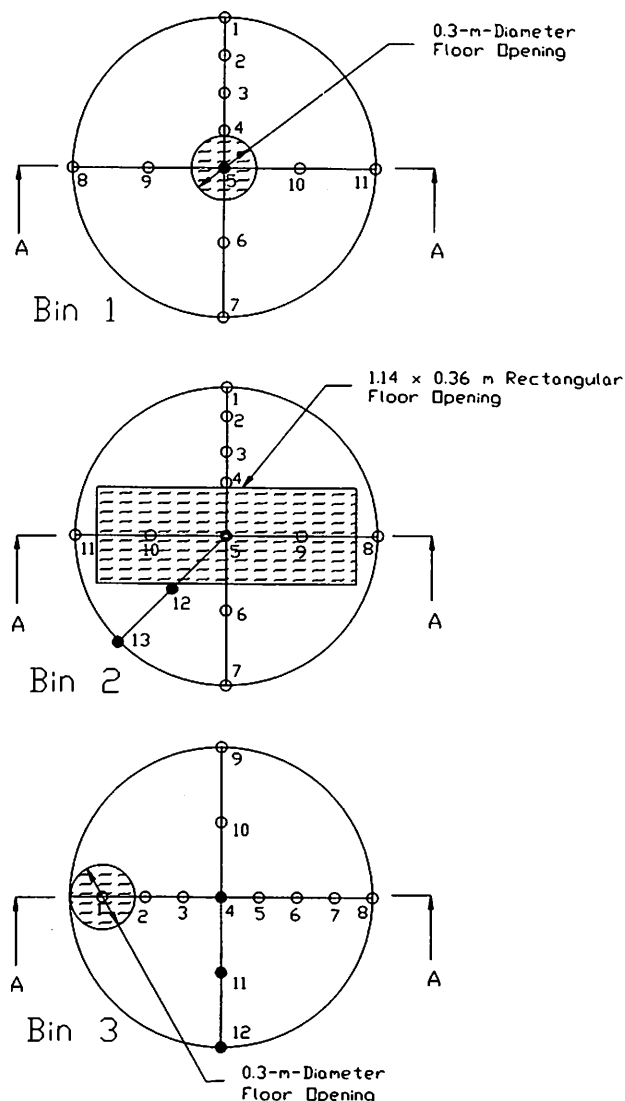

**Fig. 1. Schematic diagram of temperature and gas sampling locations in 1.42 m diameter by 1.47 m tall bins. The bins were filled with wheat to a depth of 1.37 m in the experiments. (● - temperature and gas samples; ○ - only gas samples).**

causes any effect in CO<sub>2</sub> distribution. In addition to these tests, three replicates with 540 g of dry ice in Bin 1 and Bin 2, three replicates with 740 g dry ice in Bin 2 were also conducted. Different masses of dry ice were used in different experiments to test the model with various quantities of dry ice input. Grain temperatures and gas samples were collected at 1, 3, 6, 9, 12, and 21 h after the introduction of the dry ice. The gas sampling tubes were flushed out by withdrawing about 5 mL of gas and then about 8 mL of gas were withdrawn for analysis. These gas samples were analyzed for CO<sub>2</sub> concentrations using a gas chromatograph (Perkin-Elmer model Sigma 3B) with a thermal conductivity detector and a 1 mL fixed volume injection loop. In all the bins, experiments

were conducted with both open and covered grain surfaces. For covering the grain surface, a polyvinylidene chloride sheet (made of 3 layers of nylon and 4 layers of polyethylene, PVDC) which had a CO<sub>2</sub> permeability rate of <0.1 mL•m<sup>-2</sup>•d<sup>-1</sup> (Winpak, Winnipeg, MB) was used. The covering sheet was taped to the bin wall using duct tape.

The grain was aerated using a 1.5 kW centrifugal fan for about 1 h immediately after each replicate and for about 15 min just before the next replicate to bring the intergranular CO<sub>2</sub> concentrations to atmospheric level. The grain was left undisturbed for about 24 h between replicates. Grain samples were collected after each experiment for determining the moisture content. The moisture contents of the wheat samples were determined by drying triplicate samples of about 15 g each in an air convection oven at 130°C for 19 h (ASAE 1992).

## RESULTS AND DISCUSSION

### Grain moisture content and temperature

The moisture content of the wheat did not vary appreciably during the course of the experiments. The average moisture content of the wheat used in the experiments was 12.6±0.4% (wet basis). The maximum observed deviation from the mean grain temperature in any experiment was ±2.7°C (Table I).

### Iso-concentration lines

Lines of constant CO<sub>2</sub> concentrations along section A-A of Bins 1, 2 and 3 (Fig. 1) were drawn by interpolating the measured CO<sub>2</sub> concentrations at various locations, separately at all sampling times. A typical plot, drawn using the CALCOMP plotting subroutines (University of Manitoba Computer Services), for the mean CO<sub>2</sub> concentrations of three replicates in Experiment 1 is shown in Fig. 2. During the initial few hours after the introduction of dry ice, the CO<sub>2</sub>

gas flooded along the bin floor. In Bin 1, for example, 1 h after the introduction of dry ice the CO<sub>2</sub> concentrations near the wall in the horizontal direction reached about 10% while a point at the same distance in the vertical direction had a concentration of only about 2% (the 10 and 2% concentration lines in Fig. 2). In Bin 2, with an input of 370 g of dry ice, near sampling points 1 and 7 (0.53 m from the floor opening) the CO<sub>2</sub> concentrations reached about 22% at 3 h while at a point about 0.66 m above the floor along the central axis the concentration reached only about 5%. Similar high CO<sub>2</sub> concentrations in the lower portions of the wheat bulk were observed with 540 g of dry ice in Bin 1 and 740 g of dry ice in Bin 2. The flooding of CO<sub>2</sub> in the lower regions of the wheat bulks might be because of the following reasons:

1. Carbon dioxide is about 1.5 times as heavy as air (at atmospheric pressure the density of CO<sub>2</sub> at a temperature of 20°C is 1.832 kg/m<sup>3</sup> compared with the density of air of 1.189 kg/m<sup>3</sup> at the same temperature). The gravity forces acting on the heavier CO<sub>2</sub> molecules tend to retard their rate of movement in the vertically upward direction.
2. When dry ice sublimates into CO<sub>2</sub> gas it creates a slow releasing pressure. For example, 180 g dry ice would create an absolute pressure of 107.8 kPa at 20°C in the dry ice box of Bin 1 (Fig. 1) if the box was perfectly sealed. This pressure causes a bulk movement of CO<sub>2</sub> through the grain mass. The resistance of grains and oilseeds to bulk flow of air is lower in the horizontal direction than in the vertical direction (Kumar and Muir 1986; Jayas et al. 1987; Alagusundaram et al. 1992). Wheat has about 30 to 60% higher resistance to airflow in the vertical direction than in the horizontal direction (Kumar and Muir 1986). Because of the lower resistance to flow in the horizontal direction, the bulk

**Table I: Wheat bulk temperatures (°C) and  $\eta_r$  in various pilot bin experiments**

Experiment	Mass of dry ice (g)	Temperatures (°C)				$\eta_r$ (%)
		Replicate 1 Mean ± SD**	Replicate 2 Mean ± SD	Replicate 3 Mean ± SD	Experiment* Mean ± SD	
Bin 1 open grain surface	180	24.0 0.6	27.2 0.8	26.0 0.8	25.7 1.6	43.4
Bin 1 open grain surface#	180					42.9
Bin 1 covered grain surface	180	16.5 2.3	17.3 2.4	17.1 2.3	17.0 2.7	54.6
Bin 1 open grain surface	540	23.4 2.0	22.7 0.6	19.8 0.9	21.9 2.0	43.7
Bin 2 open grain surface	370	19.7 0.7	19.5 1.8	23.2 2.1	20.7 2.3	43.8
Bin 2 covered grain surface	370	24.7 1.1	26.0 1.2	28.9 1.3	26.5 2.1	50.1
Bin 2 covered grain surface	740	26.5 0.7	27.1 1.0	28.0 0.7	27.2 1.0	41.7
Bin 3 open grain surface	180	27.3 1.5	29.0 2.0	27.2 1.5	27.8 1.9	44.9
Bin 3 covered grain surface	180	23.5 1.2	24.7 1.3	21.9 1.6	23.2 1.7	50.5

\* The measured temperatures in all three replicates were averaged.

\*\* Standard deviation

# Temperatures were not recorded. The bin was emptied and refilled after each replicate. In other tests, a bin was filled once for three replicates but grain was aerated between replicates.

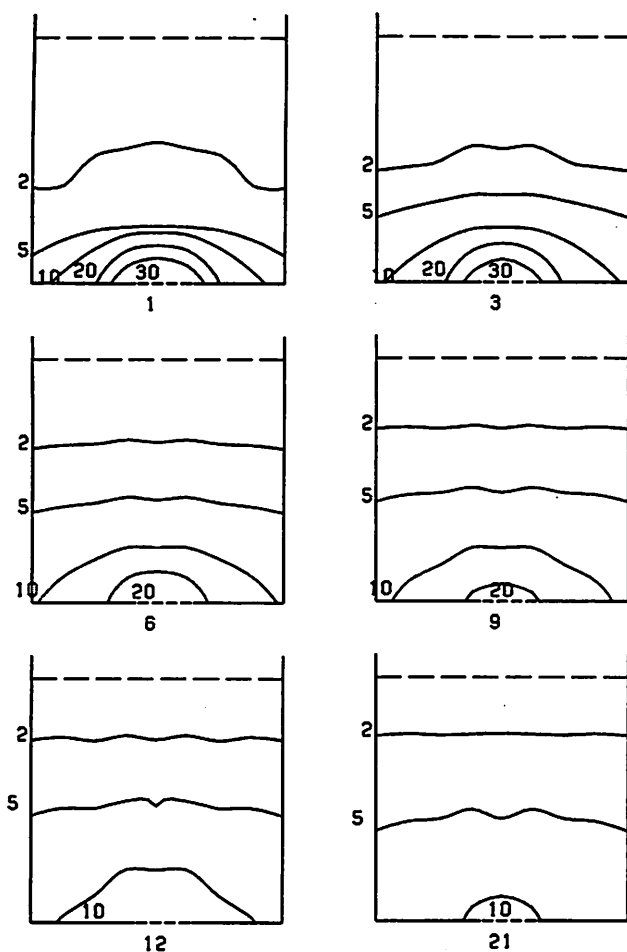

**Fig. 2.** Lines of constant CO<sub>2</sub> concentrations (%) along section A-A (Fig. 1) of a 1.42 m diameter bin containing wheat to a depth of 1.37 m with open top surface at various sampling times after the introduction of 180 g of dry ice under a 0.3 m diameter perforated floor opening at the centre (Bin 1). (The numbers beneath each cross-section indicate the sampling time (h)).

movement of CO<sub>2</sub> gas may be more in the horizontal direction than in the vertical direction.

Once the pressure created by the dry ice sublimation is dissipated, the CO<sub>2</sub> moves through the bulk by molecular diffusion. At atmospheric pressure, the coefficient of diffusion is the same in both the horizontal and the vertical directions (Singh et al. 1984). Six hours or later after the introduction of dry ice, CO<sub>2</sub> concentrations in the top two-thirds of the wheat bulks were nearly uniform in the horizontal direction. There were gradients in the vertical direction. For an effective control of insects using modified atmospheres, the introduced gases should be uniformly distributed in the grain bulk and a minimum required CO<sub>2</sub> concentration (about 35%) should be maintained at all locations in the grain bulk. Although, in the bottom portions, CO<sub>2</sub> was not distributed uniformly in the horizontal direction the concentrations

were higher than in the top portions. When using CO<sub>2</sub> to kill insects, care should be taken to check the CO<sub>2</sub> levels in the top portions of the grain bulk.

Guiffre and Segal (1984), while discussing the practical aspects of CA storage, cautioned that layering of CO<sub>2</sub> in the bottom portions of the grain bulk will reduce concentrations in the top portions. To attain uniform CO<sub>2</sub> concentrations throughout the grain bulk in large silos, it is often essential to recirculate the intergranular air from bottom to top using a fan and a piping system (Jay et al. 1970; Wilson et al. 1980; Navarro et al. 1986). Our results indicate that small inlet areas for CO<sub>2</sub> (0.071 m<sup>2</sup> in Bins 1 and 3 and 0.41 m<sup>2</sup> opening in Bin 2) or the location of the floor opening (near the centre in Bin 1 and near the wall in Bin 3) did not reduce the uniformity of CO<sub>2</sub> distribution in the horizontal direction in the top regions of the bulk. Therefore, in an existing farm bin with a concrete floor, it should be possible to introduce the dry ice through the auger inlet opening in the door.

#### Variation among replicates

The coefficient of variation among three replicates was less than 10% for 75% of the samples in all the experiments. For 98% of the samples the coefficient of variation among replicates was less than 25%. Maximum deviations were observed near the grain surface where the CO<sub>2</sub> concentrations were usually low. At sampling level 5, which was only 0.05 m below the grain surface, small undulations in the grain surface could cause relatively large errors in the measured CO<sub>2</sub> concentrations. For example, a difference of 0.02 percentage points in a CO<sub>2</sub> concentration of 0.05% causes an error of 40% while at a CO<sub>2</sub> concentration of 10% the error is only 0.2%.

#### Effect of emptying and refilling

Statistical t-tests were performed to compare the means of the measured CO<sub>2</sub> concentrations at various locations and at various times in different experiments. This analysis indicated that the CO<sub>2</sub> concentrations in a bulk that was refilled after each replicate were not significantly different ( $\alpha=0.05$ ) from a bulk that was not refilled after each replicate. Out of 264 sample measurements, 212 were not significantly different. The wheat used in the experiments was relatively free of foreign material (0.5% foreign material). In a farm bin, however, the in-situ bulk density of grain in a bin may vary because of filling method or distribution of foreign material. For example, when a farm bin is filled with canola containing chaff and fines, the fine materials tend to fall near the centre and near the wall of the bin and the chaff is distributed near the bin wall (Jayas 1987). The reduced porosity or the different porosities in different regions of the bulk will alter the pattern and the rate of movement of the CO<sub>2</sub> gas through the bulk. Jay and Pearman (1973), in their study on controlling natural insect infestations in a corn bulk, observed low CO<sub>2</sub> concentrations at locations where the accumulation of dust and foreign material were the highest. They hypothesized that uniform CO<sub>2</sub> concentrations in the bulk could be achieved quickly if the foreign material content was less. Further experiments in large grain bulks with different foreign material contents should be conducted to study the effect of filling method and the distribution of foreign material on

the distribution of CO<sub>2</sub>.

### Effect of open and covered grain surface

The means of the measured CO<sub>2</sub> concentrations at various locations in open and covered grain surfaces were compared using statistical t-tests. In Bin 1, 159 out of 209 CO<sub>2</sub> samples, in Bin 2, 110 out of 247 samples, and in Bin 3, 123 out of 288 samples in a grain bulk with open grain surface were significantly different ( $\alpha=0.05$ ) from samples in a grain bulk with covered grain surface. The major effect of covering the grain surface was to increase the CO<sub>2</sub> concentrations near the top portions of the bulk. In all three bins, most CO<sub>2</sub> samples at the top three levels (97% of samples in bin 1, 92% in Bin 2, and 94% in Bin 3) in covered grain bulks were significantly higher than the uncovered bulks. For example, 21 h after the introduction of dry ice, the average CO<sub>2</sub> concentration at the top level, with 370 g of dry ice in Bin 2 with open grain surface was 0.7% compared with 8.9% when the grain surface was covered with a PVDC sheet. Thus, covering the grain surface is effective in retaining CO<sub>2</sub>.

McGaughey and Akins (1989), based on their study of CA treatment of grains in corrugated steel bins, found that the gas requirement in an uncovered grain bulk was 10 times more than the gas requirement in a covered grain bulk for creating the same levels of CO<sub>2</sub> concentrations in both the grain bulks. For a CA treatment in non-airtight bins, it will be necessary to cover the grain surface with a PVDC sheet to create high concentrations in the top portions of the bulk.

### Effect of the mass of introduced dry ice

As expected, increasing the amount of dry ice increased the CO<sub>2</sub> concentrations significantly. In Bin 1, with 540 g of dry ice the CO<sub>2</sub> concentrations in 242 out of 264 samples were higher than with 180 g dry ice. In Bin 2, 740 g dry ice increased CO<sub>2</sub> concentrations at 259 out of 286 samples over the 370 g dry ice. However, the increase in the intergranular CO<sub>2</sub> concentrations were not proportional to the increased input of dry ice.

### Comparison of efficiency of retention in different experiments

In several experiments, the mass of dry ice used and the duration of the experiment were different. To compare various experiments we estimated efficiency of retention ( $\eta_r$ ) using:

$$\eta_r = \frac{\text{Cumulative ct-product} \times 100\%}{\text{NDV of CO}_2 \times t \times C_{th}} \quad (1)$$

where:

$C_{th}$  = CO<sub>2</sub> concentration that would have been created by one domain volume of CO<sub>2</sub> gas, if all the introduced CO<sub>2</sub> gas stayed in the domain and none was adsorbed by the grain (%),

NDV of CO<sub>2</sub> = number of domain volumes of CO<sub>2</sub> (ratio of the volume of CO<sub>2</sub> used to the domain volume), and

$t$  = duration of the experiment (h).

The cumulative ct-product was estimated using (Alagusundaram 1993):

$$\text{cumulative ct-product} = \sum_{i=1}^n [C_a \Delta t]_i \quad (2)$$

where:

$C_a$  = average between two sampling times of measured CO<sub>2</sub> concentrations weighted over a sub-divided volume (%),

$n$  = number of sampling times, and

$\Delta t$  = time difference between two sampling times (h).

The calculated retention efficiencies using the above procedure are given in Table I. The  $\eta_r$  reported in Table I are at the end of each experiment. Higher  $\eta_r$  were observed in wheat bulks with the covered grain surfaces than in bulks with the uncovered grain surfaces. For example, in Bin 1 with an open grain surface the  $\eta_r$  was 43% compared with 55% when the grain surface was covered (Table I), further supporting that covering the grain surface improves the retention of CO<sub>2</sub> in the grain bulk. In none of the pilot-bin experiments was the  $\eta_r$  more than 55%. The low values of  $\eta_r$  could be because of the following reasons:

1. At 21 h after the introduction of dry ice some CO<sub>2</sub> remained in the dry ice box (which replenished the CO<sub>2</sub> in the grain bulk). For example, in the dry ice box of Bin 1 with an open grain surface 19.8 g of CO<sub>2</sub> gas, which is about 11% of the total input, remained in the box at 21 h.
2. In an uncovered grain bulk the CO<sub>2</sub> gas escaped through the top grain surface to the surrounding atmosphere.
3. In both the covered and the uncovered grain bulks the wheat contained in the bins sorbed (adsorbed and absorbed) a certain amount of CO<sub>2</sub> gas. Cofie-Agblor et al. (1993) estimated that in 24 h, at 100% concentration the amount of CO<sub>2</sub> gas sorbed by wheat ranges from 0.18 g/kg to 0.42 g/kg at a moisture content of 18% and at temperatures ranging from 0 to 30°C. Linearly extrapolating these figures for a CO<sub>2</sub> concentration of 10%, in Bin 1 with 180 g dry ice input and covered grain surface the amount of CO<sub>2</sub> sorbed could be 62 g or 0.04 g/kg of wheat. When treating a large grain bulk with CO<sub>2</sub>, allowances should be made for the sorption of CO<sub>2</sub> by the grain.
4. Even in sealed bins (5 min pressure decay time from 500 to 250 Pa), a gas exchange rate of 4 to 7% per day is unavoidable (Banks et al. 1980). It is probable that during the 21 h experiment, some CO<sub>2</sub> was lost to the atmosphere.

Increasing the amount of dry ice did not increase the  $\eta_r$ . For example, in Bin 1 with an uncovered grain surface, both the 540 g and 180 g of dry ice resulted in nearly the same  $\eta_r$ . On the other hand, in Bin 2 with a covered grain surface, 740 g of dry ice resulted in a reduced  $\eta_r$ . A probable reason for this could be that the sorption of CO<sub>2</sub> by the wheat would have increased with the increased dry ice input (the wheat contained in Bin 2 could sorb a maximum of 694 g of CO<sub>2</sub> at an initial CO<sub>2</sub> concentration of 100%).

## CONCLUSIONS

Based on the results of this study the following major conclusions can be drawn:

1. During the initial few hours after the introduction of dry ice, the sublimated CO<sub>2</sub> gas flooded into the bottom portions of the wheat bulks.
2. Irrespective of the shape and location of the floor opening, the CO<sub>2</sub> concentrations were uniform in the horizontal direction in the top two-thirds of the grain bulk.
3. Covering the grain surface with a PVDC sheet resulted in higher CO<sub>2</sub> concentrations in the wheat bulks.
4. Emptying and refilling the bin did not cause any significant difference in the observed CO<sub>2</sub> distribution in the grain bulk. Increasing the mass of introduced dry ice, however, significantly increased the observed CO<sub>2</sub> concentrations.
5. The efficiency of retention ( $\eta_r$ ) was higher when the grain surface was covered with a PVDC sheet. During CA treatment of wheat, allowances must be made for the sorption of CO<sub>2</sub> gas by the grain.

## ACKNOWLEDGEMENT

We thank the Natural Sciences and Engineering Research Council of Canada for funding this study and Messrs. Danny D. Mann, Dale P. Muir, Jack G. Putnam, and Rob Ataman for their technical assistance.

## REFERENCES

- Alagusundaram, K. 1993. Movement of CO<sub>2</sub> gas, introduced as solid formulation, through stored wheat bulks. Unpublished Ph.D. thesis, University of Manitoba, Winnipeg, MB.
- Alagusundaram, K., D.S. Jayas, F. Chotard and N.D.G. White. 1992. Airflow pressure drop relationships of some specialty seeds. *Sciences des Aliments* 12: 101-116.
- Alagusundaram, K., D.S. Jayas, W.E. Muir, N.D.G. White and R.N. Sinha. 1996. Finite element model of three-dimensional movement of carbon dioxide in grain bins. *Canadian Agricultural Engineering* 38:75-82.
- ASAE. 1992. Standard S 352.2 - Moisture measurement - unground grain and oilseeds. In *ASAE Standards 1992*. St. Joseph, MI: ASAE.
- Banks, H.J. and P.C. Annis. 1977. Suggested procedures for controlled atmosphere storage of dry grain. Technical Paper 13. Division of Entomology, Commonwealth Scientific and Industrial Research Organization, Canberra, Australia.
- Banks, H.J., P.C. Annis, R.C. Henning and A.D. Wilson. 1980. Experimental and commercial modified atmosphere treatments of stored grain. In *Controlled Atmosphere Storage of Grains*, ed. J. Shejbal, 207-224. Amsterdam, The Netherlands: Elsevier Scientific Publishing Company.
- Champ, B.R. 1986. Occurrence of resistance to pesticides in grain storage pests. In *Pesticides and Humid Tropical Grain Storage Systems*, eds. B.R. Champ and E. Highley, 229-255. Proceedings No. 14. Australian Centre for International Agricultural Research, Canberra, Australia.
- Cofie-Agblor, R., W.E. Muir, S. Cenkowski and D.S. Jayas. 1993. Carbon dioxide gas sorption by stored wheat. In *Proceedings of the International Conference on Controlled Atmosphere and Fumigation in Grain Storages*, eds. S. Navarro and E. Donahaye, 261-269. Jerusalem, Israel: Caspit Press Ltd.
- Freeman, J.A. 1973. Problems of infestation by insects and mites of cereals stored in Western Europe. In *Preservation of Wet Harvested Grains - International Symposium*, eds. J.L. Multon and A. Guilbot, 369-390. Paris, France.
- Guiffre, V. and A.I. Segal. 1984. Practical approaches to purging grain storages with carbon dioxide in Australia. In *Controlled Atmosphere and Fumigation in Grain Storages*, ed. B.E. Ripp, 343-351. Amsterdam, The Netherlands: Elsevier Scientific Publishing Company.
- Jay, E.G. and G.C. Pearman Jr. 1973. Carbon dioxide for control of an insect infestation in stored corn (maize). *Journal of Stored Products Research* 9:25-29.
- Jay, E.G., L.M. Redlinger and H. Laudani. 1970. The application and distribution of carbon dioxide in a peanut (groundnut) silo for insect control. *Journal of Stored Products Research* 6:247-254.
- Jayas, D.S. 1987. Resistance of bulk canola oilseed to airflow. Unpublished Ph.D. thesis. Department of Agricultural Engineering, University of Saskatchewan, Saskatoon, SK.
- Jayas, D.S., B. Khangura and N.D.G. White. 1991. Controlled atmosphere storage of grains. *Postharvest News and Information* 2:423-427.
- Jayas, D.S., S. Sokhansanj, E.B. Moysey and E.M. Barber. 1987. The effect of airflow direction on the resistance of canola (rapeseed) to airflow. *Canadian Agricultural Engineering* 29:189-192.
- Kumar, A. and W.E. Muir. 1986. Airflow resistance of wheat and barley affected by airflow direction, filling method and dockage. *Transactions of the ASAE* 29:1423-1426.
- McGaughey, W.H. and R.C. Akins. 1989. Application of modified atmospheres in farm grain storage bins. *Journal of Stored Products Research* 25:201-210.
- Navarro, S., T.G. Amos and P. Williams. 1981. The effect of oxygen and carbon dioxide gradients on the vertical dispersion of grain insects in wheat. *Journal of Stored Products Research* 17:101-107.
- Navarro, S., E.G. Jay and J.G. Leesch. 1986. Recirculation rate requirements for adequate distribution of carbon dioxide in grain bins. *Transactions of the ASAE* 29:1348-1354.
- Singh, D., W.E. Muir and R.N. Sinha. 1984. Apparent coefficient of diffusion of carbon dioxide through samples of cereals and rapeseed. *Journal of Stored Products Research* 20:169-175.

- White, N.D.G. and D.S. Jayas. 1992. Effectiveness of carbon dioxide in compressed gas and solid formulation on insects and mites in stored wheat and barley. *Phytoprotection* 74:101-111.
- White, N.D.G., D.S. Jayas and R.N. Sinha. 1990. Carbon dioxide as a control agent for the rusty grain beetle (Coleoptera: Cucujidae) in stored wheat. *Journal of Economic Entomology* 83:277-288.
- White, N.D.G. and S.R. Loschiavo. 1985. Testing for malathion resistance in field collected populations of *Cryptolestes ferrugineus* (Stephens) and factors affecting the reliability of tests. *Journal of Economic Entomology* 78:511-515.
- Wilson, A.D., H.J. Banks, P.C. Annis and V. Guiffre. 1980. Pilot commercial treatment of bulk wheat with CO<sub>2</sub> for insect control: the need for gas recirculation. *Australian Journal of Agriculture and Animal Husbandry* 20:618-624.