

Mechanical compaction of flour: The effect of storage temperature on dough rheological properties

S. CENKOWSKI¹, J.E. DEXTER² and M.G. SCANLON³

¹Department of Biosystems Engineering, 438 Engineering Building, University of Manitoba, Winnipeg, MB, Canada R3T 5V6;

²Grain Research Laboratory, Canadian Grain Commission, 1404-303 Main Street, Winnipeg, MB, Canada R3C 3G8; and

³Department of Food Science, Ellis Building, University of Manitoba, Winnipeg, MB, Canada R3T 2N2. Received 9 August 1998; accepted 12 January 2000.

Cenkowski, S., Dexter, J.E. and Scanlon, M.G. 2000. **Mechanical compaction of flour - The effect of storage temperature on dough rheological properties.** *Can. Agric. Eng.* 42:033-041. The effects of storage temperature, storage time, and compaction of compressed flour on functional and rheological properties of dough were investigated for flour milled from No. 1 Canadian Western Red Spring wheat. Untreated (loose) flour and flour that had been mechanically compacted to a 55% volume reduction were stored for one year at 20, 30, and 40°C. An imitative rheological test (capillary rheometry) indicated that compaction of 75% extraction rate flour had a marked effect on the magnitude of the flow behaviour index (n). This effect was not observed in 83% extraction rate flour. Storage time had a substantial effect on all samples, increasing the n values by 5 to 15%. A similar effect was observed for consistency coefficient. Alveograph and farinograph results indicated that the main factor affecting the oxidation of compacted and loose flours during storage was the storage temperature. Compaction of flour appeared to have a slight mitigating effect on changes to alveograph curves during storage. Storage of flour up to 30°C caused changes in dough rheological parameters, indicating a dough strengthening effect. Storage of flour at 40°C resulted in tight inextensible dough that would be difficult to process in bakeries. Capillary extrusion tests confirmed that the flow behaviour index was noticeably affected by storage temperature.

Les effets de la température d'entreposage, de la durée de l'entreposage et de la compaction de la farine sur les propriétés fonctionnelles et rhéologiques de la pâte furent examinés. Les expériences furent faites avec de la farine obtenue par la mouture de blé roux de printemps catégorie no. 1 de l'ouest canadien. De la farine non-traitée (non comprimée) et de la farine comprimée mécaniquement jusqu'à 55 % de réduction de volume furent entreposées durant un an à 20, 30 et 40°C. Un test de simulation des comportements rhéologiques (rhéométrie capillaire) montra que la compression de farine ayant un taux d'extraction de 75 % avait un effet important sur l'indice d'écoulement (n). Cet effet ne fut pas observé avec de la farine ayant un taux d'extraction de 83 %. La durée de l'entreposage eut un effet substantiel sur tous les échantillons, provoquant une augmentation de 5 à 15 % des valeurs de n. On observa un effet semblable sur le coefficient de consistance. Les résultats des alvéographes et des farinographes montrèrent que la température d'entreposage était le facteur qui affectait le plus l'oxydation des farines non-comprimées et comprimées. La compaction de la farine semble atténuer les changements observés sur les alvéographes lors de l'entreposage. L'entreposage de la farine à des températures atteignant 30°C provoqua des changements dans les paramètres rhéologiques de la pâte qui indiquaient un raffermissement. La farine entreposée à 40°C produisit une pâte serrée peu extensible et qui serait difficile à

travailler en boulangerie. Les tests d'extrusion capillaire confirmèrent que l'indice d'écoulement était sensiblement affecté par la température d'entreposage.

INTRODUCTION

Moisture migration and air (oxygen) diffusion into flour can lead to both physical and chemical changes that can affect the quality of the baked goods. Untreated flour milled from recently harvested wheat normally improves in baking quality within a period of 1-2 months (Kent 1983). The improvement, or maturation, occurs more rapidly if the stored flour is exposed to aeration, but at the same time oxidation of fatty acids takes place which has been shown to be associated with decreased baking quality (Warwick et al 1979; Yoneyama et al. 1970). The maturation of flour can be accelerated by adding chemical improvers (i.e., chlorine, chlorine dioxide, ascorbic acid, azodicarbonamide, potassium bromate). However, upon further storage, flour which has been artificially matured tends to deteriorate in baking quality more rapidly than untreated flour (Cuendet et al. 1954). Also, regulations regarding flour composition are revised every several years with a tendency to restrict or even eliminate the use of some chemical improvers (Kent 1983).

It is known that variation in baking performance during storage is dependent on such factors as moisture content, storage temperature, and storage atmosphere (Bell et al. 1979; Warwick et al. 1979). The transfer of moisture or oxygen is controlled by thermodynamic and dynamic processes. The rate of transfer can be reduced in a multi-domain product like flour if it is mechanically treated to create as small a pore size and pore size distribution as possible (Labuza and Hyman 1998). Reduction of flour volume by mechanical compression or compaction of flour could offer advantages for long term storage. Compaction would reduce storage volume, slow down diffusion of oxygen into the flour during storage and, therefore, reduce oxidative processes and improve storage stability. Also, compacted flour would have more resistance to possible infestation by mites or other micro-organisms.

Information on rheological properties of dough is used in quality control of raw materials used in baked products. The importance of the fundamental rheological properties of the

Table I. Average values (n=3) of equilibrium moisture contents for the two grades of flour (75 and 83% extraction rate) compacted and non-compacted (loose) stored for one year at 20, 30, and 40°C. The standard deviation for all samples was in the range of 0.1% wb.

Extraction yield (%)	Storage temperature (°C)	Equilibrium moisture content (% wb)	
		Loose	Compacted
75	20	8.8	9.4
	30	5.1	5.8
	40	2.8	3.1
83	20	8.9	9.7
	30	5.8	5.7
	40	2.1	2.2

dough and evaluation methods have been described by many authors (see for example Hibberd and Parker 1975; Bushuk 1985; Hosenev 1985; Loh 1985; Faubion and Hosenev 1989; Menjivar 1989). Measurements of these properties are widely used for the selection of new cultivars in breeding, for quality control in mills and bakeries, and in the design and adaptation of processes in the milling and baking industries (Blokma 1990). The effects of compaction of two grades of flour on its thermodynamic (Gibbs free energy changes, water activity, heat of sorption and desorption, monolayer coverage values) and functional properties (rheological tests, including farinograph, mixograph, viscoamylograph, alveograph, wet gluten content, short baking test, and capillary rheometer tests) were investigated by Cenkowski et al. (1998). In general, mechanical compaction itself and reconstitution of flour had no adverse influence on these properties.

It is well known that under ideal storage conditions, flour retains its functionality for several years (Tsen and Dempster 1963; Bell et al. 1979). However, at high temperature, such as often occurs in tropical countries and may occur in continental climates during summer, the rate of deterioration is accelerated. The effect of storage temperature of flour (10 to 30°C range) on bread baking characteristics was investigated by Wolter (1986). Flour stored at 25°C showed a greater rate of deterioration reflected in more rapid lipolysis compared with flour stored at 12°C (Bell et al. 1979).

The objective of this research was to compare the effect of storage temperature of mechanically compacted flour and loose flour on functional and rheological properties of flour and flour-water dough.

MATERIALS and METHODS

No 1 Canadian Western Red Spring (CWRS) wheat harvested in 1994 was milled in a pilot scale flour mill (Preston and Dexter 1994) in June 1995. Two grades of flour were prepared, a lower extraction (75%) and a higher extraction (83%) flour. The protein content (%N X 5.7, method 46-12, AACC 1995), ash (method 08-01, AACC 1995), and moisture (method 44-15A, AACC 1995) contents, and falling number (method 107, ICC 1980) of wheat were 13.4%, 1.70, 13.5 wet basis (wb), and 410 s, respectively. Protein and ash contents were 13.0% and 0.49%, respectively, in the lower extraction flour, and 13.6% and 0.75%, respectively, in the higher extraction flour, 14.0 wet basis. Both flours after milling had 13.5% wb moisture.

Samples of both flours were compacted in a metal cylinder whose inside diameter and height were 27 and 235 mm, respectively. Loose flour (64 g) was placed in the cylinder and compressed by a plunger at a speed of 100 mm/min until a 55% volume reduction was reached. The average pressure exerted on the flour was between 7.0 and 8.0 MPa. The compacted cylindrical-in-shape flour discs were then carefully pushed out from the metal cylinder and stored for a year at three temperatures: 20, 30, and 40°C at corresponding relative humidities (RH) of 40, 20, and 10%. The variability in RH for samples stored at 20°C was in the range of $\pm 7\%$, while for the flour stored at 20 and 30°C the RH range was $\pm 3\%$. Also, loose flour was stored in 1 kg lots in paper bags as controls and stored under the same storage conditions. Table I shows the average equilibrium moisture content (EMC) of compacted and loose flour of two grades (75 and 83% extraction yield) after one year of storage at 20, 30, and 40°C.

A capillary rheometer was used to obtain information on flow behaviour of the dough prepared using compacted and loose flour samples of both flour grades. The compacted flour samples were reconstituted using a juicer (Model G-5 NG853S, Plastaket Manufacturing Inc., Lodi, CA) as this technique did not affect water absorption (Cenkowski et al. 1998). The tests took place after 1 to 3 months of storage and after 12 months of storage. Table II shows the schedule of testing.

The rheometer consisted of a 136 mm long brass cylinder with an inside diameter of 19.1 mm, a tight-fit stainless steel

Table II. Schedule of capillary extrusion tests. The ticks indicate the storage time of each. Numbers 20, 30, and 40° indicate the storage temperatures (°C).

Storage time (months)	75% extraction yield						83% extraction yield					
	Loose			Compacted			Loose			Compacted		
	20°	30°	40°	20°	30°	40°	20°	30°	40°	20°	30°	40°
1				✓						✓	✓	✓
2		✓			✓			✓				✓
3	✓		✓			✓	✓					
12	✓	✓	✓	✓	✓	✓	✓	✓	✓	✓	✓	✓

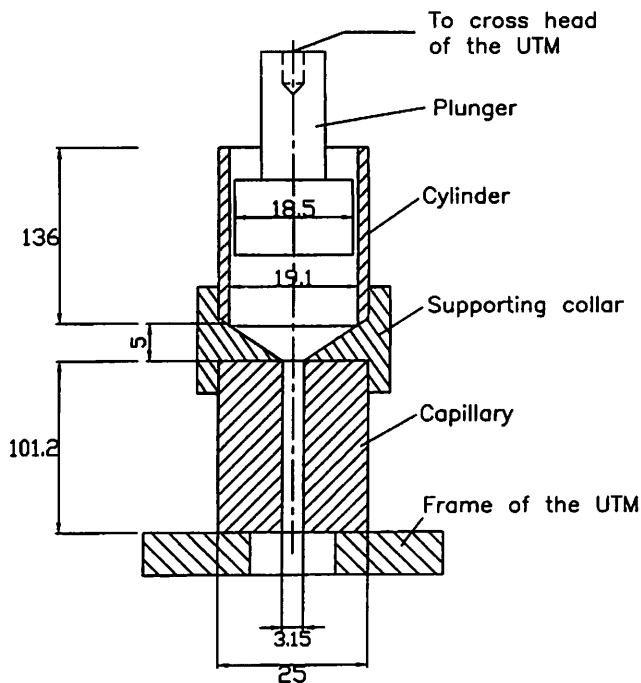

Fig. 1. Capillary rheometer. All dimensions are in mm.

plunger (18.5 mm diameter), and a brass capillary tube with an inside diameter of 3.15 mm and a length of 101.2 mm (Fig. 1). The capillary tube was screwed into the supporting collar of the cylinder which rested on the frame of an ATS Universal Testing Machine (UTM) (Applied Test Systems, Inc., Butler, PA). The plunger was attached to the cross head of the UTM and was used to push the dough through the cylinder with or without a capillary attached.

For the capillary extrusion tests, dough was prepared in a pin mixer (Model CB 1284, Muzeen and Blymthe Ltd., New Port, RI) (Hlynka and Anderson 1955). The amount of water added to flour was equivalent to farinograph water absorption. The dough (300 g flour) was mixed in the pin mixer until it reached optimum mixing time, the time required by the dough to reach the maximum consistency. The dough was allowed to relax for 30 min in a sealed plastic box at room temperature (19

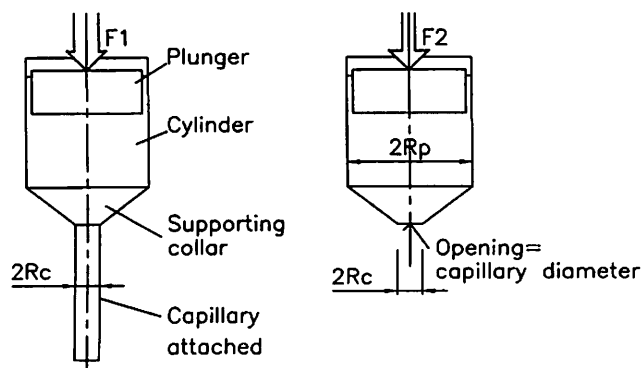

Fig. 2. Measured forces F1 and F2 in the extrusion test with and without capillary attached, respectively.

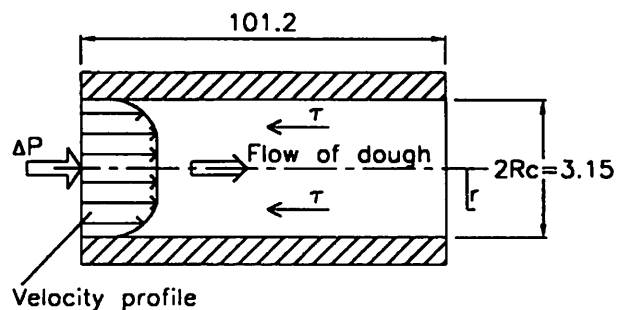

Fig. 3. Balance of applied pressure ΔP with shear stress inside the capillary and expected velocity profile for dough experiencing a pseudoplastic flow. All dimensions in mm.

- 20°C) prior to conducting the capillary extrusion tests. The inside wall of the cylinder was lubricated manually with oil to reduce friction between the wall of the cylinder and the dough. The cylinder was filled with dough. The dough was extruded at room temperature at plunger speeds of 5.0, 10.0, 20.0, 50.8, 101.1, 200.7, 350.5, and 500.4 mm/min in sequence. The extrusion tests for the same flour sample were conducted with and without the capillary set up (Fig. 2) for both flour grades. The extrusion forces measured with and without the capillary attached to the cylinder were named F1 and F2, respectively. The difference in the extrusion forces (F1-F2) divided by the cross section area of the plunger was used for the determination of the pressure necessary to extrude dough from the capillary (ΔP) (Fig. 3). The 70 g cylinder capacity accommodated 2-3 consecutive extrusions, and the 300 g dough prepared in the pin mixer was sufficient to get extrusion results on all velocities, but for only one (with or without) capillary arrangement. Due to the substantial thickness of the wall of the capillary (approximately 11 mm) and its heat absorbing capacity, the temperature of the capillary did not change over the two or three consecutive plunger speeds. An example plot illustration of typical extrusion characteristics (with and without the capillary attached to the cylinder) indicating the data averaging approach is shown in Fig 4.

Flour water absorption, dough development time (DDT), mixing tolerance index (MTI), and stability were determined using a farinograph (Brabender Instruments Inc., South Hackensack, NJ) following AACC (1995) Method 54-21. Farinographs were done twice, but the first time the dough was titrated to determine exact water absorption (which means that DDT, MTI, dough stability, etc. could not be determined accurately), and then the procedure was repeated to obtain farinograph measurements. Alveograms were obtained with an MA 82 Alveograph (Chopin SA, Villeneuve-La-Garenne, France) at 50% water addition (15% wb) as recommended in the ICC procedure (Standard No. 121, ICC 1980). Alveograph doughs were prepared once, because each test requires 250 g of flour, and sample size was limiting. Five separate dough pieces were stamped from the dough, rested, tested separately, and the results were averaged. Generally, it is expected that alveograph measurements from replicated tests will deviate about 5%.

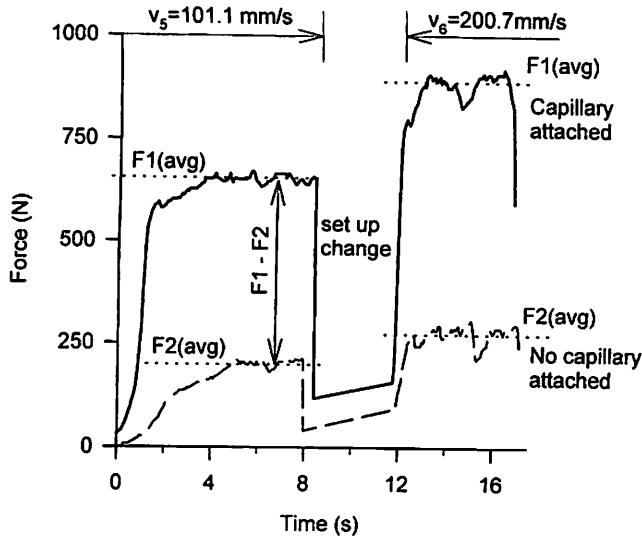

Fig. 4. Typical force-time characteristics of dough extruded at two consecutive velocities of the plunger (101.1 and 200.7 mm/s) through the capillary (thick solid line) and without the capillary attached to the cylinder (thin dashed line). The dotted lines show averaged data, F_i (avg), used in calculations of ΔP .

RESULTS and DISCUSSION

Capillary rheometry

The flow characteristics of a flour-water dough are reflected in the flow behaviour index (n) and the consistency coefficient (K). Lower values of the flow behaviour index result in a flatter velocity profile, and higher values maximise the difference between the slowest (close to the wall of the capillary) and fastest (in the centre of the capillary) fluid (dough) layers (Fig. 3).

Based on the analysis of the extrusion data (example shown in Fig. 4), plots of the shear stress versus corrected shear rate at the wall were constructed and the best fit lines were determined based on the relationship acceptable for pseudoplastic flow (Cenkowski et al. 1998):

$$\tau = K\gamma_w^n \quad (1)$$

where:

- τ = shear stress (kPa),
- K = consistency coefficient (kPa s ^{n}),
- n = flow behaviour index, and
- γ_w = corrected (at the wall) shear rate (1/s).

The corrected shear rate was determined based on the Rabinowitsch-Mooney equation as (Steffe 1992):

$$\gamma_w = \gamma \left(\frac{3}{4} + \frac{1}{4n} \right) \quad (2)$$

where: γ = apparent wall shear rate (1/s).

The apparent wall shear rate was determined based on the flow of the dough through the capillary as:

$$\gamma = \frac{4Q}{\pi R_c^3} \quad (3)$$

where:

- Q = volumetric flow rate (m³/s) and
- R_c = radius of the capillary (m).

The flow behaviour index (n) and the consistency coefficient (K) were determined by the least-squares regression analysis (Kleinbaum et al. 1988). A criterion was set to a value of 0.95 for the quantitative measure R^2 of how well the fitted model containing variables predicted the dependent variable.

Figure 5 shows the effect of storage temperature and time on n and K values for loose and compacted flour for two grades of flour and after 1 to 3 months and 12 months of storage. The effect due to compaction is visible for the 75% extraction rate flour. However, the results show that while after a short storage time (1 to 3 months) the n values for compacted flour are lower than for the loose flour; this situation is reversed after one year of storage. There was no effect on the magnitude of the flow behaviour index due to compaction for the 83% extraction rate flour (Fig. 5a and 5c). This might be attributed to small sample size (27 mm in diameter) that would permit more air (oxygen) penetration than if larger commercial-scale samples were used.

An indication of the permeability of the compacted discs to air was evident from EMC following storage. Increasing storage temperature from 20 to 40°C affected EMC of flour by lowering it from 8.8 to 2.8% wb and from 9.4 to 3.1% wb for the 75% extraction loose flour, respectively, and from 9.4 to 3.1% wb for the 75% extraction compacted flour, respectively (Table I). The difference in EMC between the compacted and loose flour was statistically significant (95% CL) at 20°C but not statistically significant at higher storage temperatures. Because the moisture content of the flour before compaction was 13.5% wb, the storage conditions (air temperature and low RH) created a positive environment for dehydration of the flour samples. As moisture movement in the compacted flour samples was more restricted than in the loose flour, the compacted flour remained at a higher EMC level, as expected. Tsen and Dempster (1963) studied the aspect of storage time and moisture content of flour on its baking strength. They concluded that lower levels of moisture in stored flour slowed down the oxidation of sulfhydryl groups responsible for deterioration of loaf properties. Perhaps in our experiments, if we had been able to maintain the initial moisture of compacted and loose flours at their original levels, oxidative effects following storage would have been more pronounced.

As storage temperature increased, flow behaviour index declined, even after 1 month of storage, except for 83% extraction rate flour (loose and compacted) that was stored for a month only. This is a significant practical finding to a miller or baker. It means that under ambient conditions typical of tropical climates and for some continental climates during summer, temperature will affect dough rheology even for

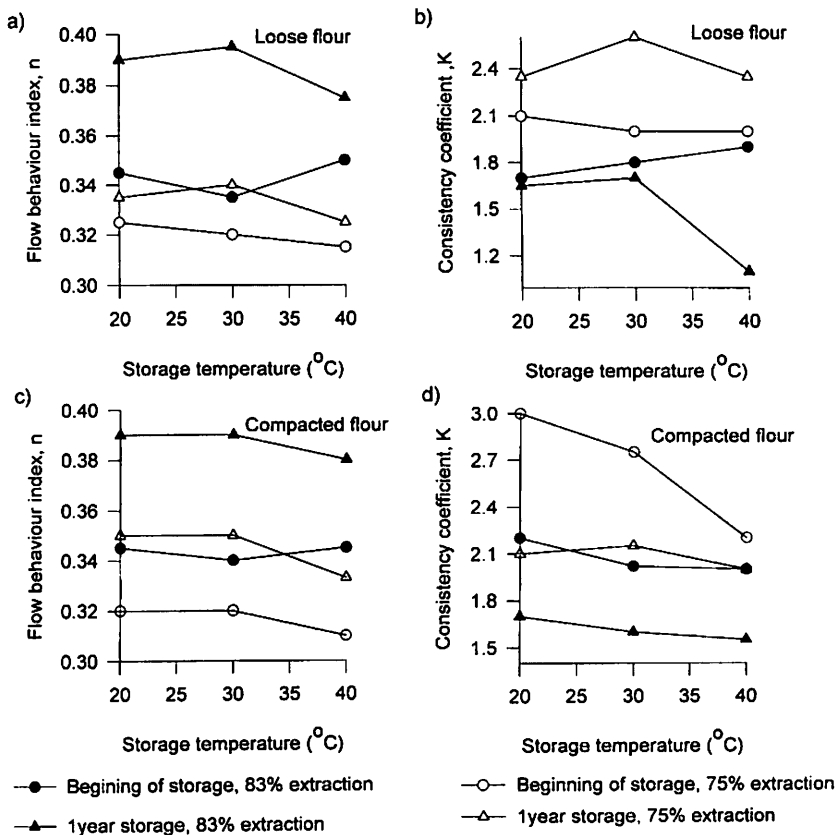

Fig. 5. (a, c) Change in flow behavior index and (b, d) consistency coefficient in loose (a, b) and compacted flour (c, d) due to storage temperature and storage time.

relatively 'fresh' flour. Storage time had quite a substantial effect on all the samples, shifting the n values to a higher magnitude by 5 to 15%.

To see the effect of flow behaviour index on the velocity profile, the relationship between the dough velocity in the capillary at a radial location of r and the volumetric average velocity was considered according to the equation (Steffe 1992):

$$\frac{u}{\bar{u}} = \left(\frac{3n+1}{n+1} \right) \left[1 - \left(\frac{r}{R_c} \right)^{(n+1)/n} \right] \quad (4)$$

where:

- r = radial distance in the capillary (m),
- u = local velocity (m/s) of fluid in a capillary at the radial distance of r , and
- \bar{u} = volumetric average velocity (m/s) of dough in the capillary which is given by:

$$\bar{u} = \frac{Q}{\pi R_c^2} \quad (5)$$

An example of the change in the laminar velocity profiles calculated according to Eq. 4 of extruded dough prepared from the 83% extraction compacted flour stored at 30°C is shown in

Fig. 6. The solid line labelled with $n = 0.34$ represents dough made from the compacted flour stored for 1 month. The dotted line labelled $n = 0.39$ shows the velocity profile for the extruded dough prepared from the same flour but stored for 1 year. The third solid line ($n=1$) shows a velocity profile of a Newtonian fluid presented for comparison purposes. The two graphs plotted for the compacted flour indicate that the velocity profile becomes less flat (which is one of the indicators of plasticity) in the central section of the capillary as storage progresses.

The consistency coefficient (K) of dough exhibited variable response to compaction, storage time, and storage temperature. Generally, the compaction of flour increased K in comparison to flour stored in bulk, except for the 75% extraction rate flour that was stored for 1 year, where compaction lowered the K value (Fig. 5b and 5d). Also, the increase in K attributable to compaction was dependent on storage temperature, but the relationship was complex.

The effect of storage time of K for loose and compacted flour shows a very clear trend. After 1 year of storage, K decreased 10 to 30% for compacted flour of both grades depending on the storage temperature. K for 75% extraction rate loose flour increased on average by 15% after 1 year of storage. It did not change for 83% extraction rate loose flour stored at 20 and 30°C but decreased almost by half for this flour stored at 40°C (Fig. 5b).

The consistency coefficient and the flow behaviour index can be used to determine the apparent viscosity, and according to Mohsenin (1986) the power law equation is:

$$\eta'' = K^{1/n} \tau^{(1-1/n)} \quad (6)$$

where: η'' = apparent viscosity coefficient (kPa s).

The apparent viscosity coefficient can then accommodate the effect of both parameters (K and n) in the analysis of the impact of compaction and storage temperature on dough. The effect of the shear stress (τ) on the apparent viscosity coefficient (η'') for the dough prepared from the 83% extraction compacted flour after 1 month of storage ($K = 2.02$, $n = 0.34$) and after 12 months of storage ($K = 1.6$, $n = 0.39$) at 30°C is shown in Fig. 7. The third plot ($K = 3.0$, $n = 0.34$) shows the effect of the consistency coefficient (K) on η'' . The greatest effect on η'' is observed within the low shear stress range. Increasing the magnitude of τ converges the η'' values. This information could be used as a guide in the design of a mechanised bakery in which dough is transported between individual unit operations through pipes. It would be important to select the appropriate pump size for transporting dough having resistance to flow that depends on viscosity, flow rate, and pipe geometry (Fig. 6 and 7).

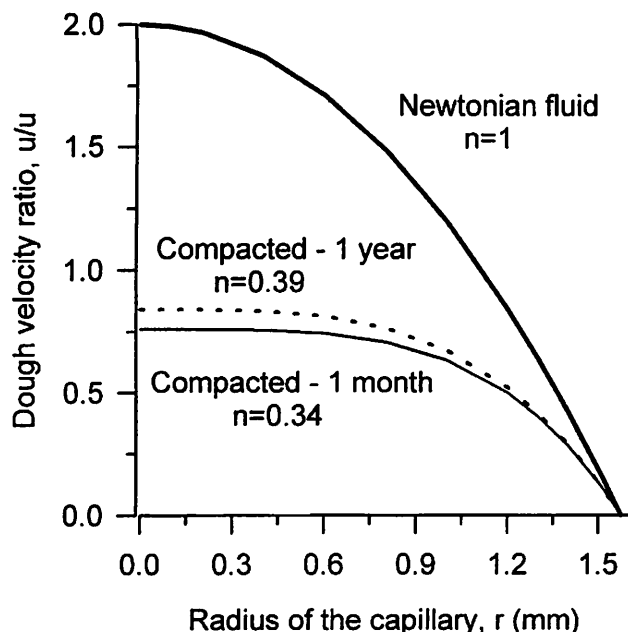

Fig. 6. Laminar velocity profiles for dough prepared from the compacted (83% extraction) flour and stored at 30°C for one month (fine line, $n=0.34$). The dotted line labelled $n=0.39$ shows the velocity profile for the same compacted flour but after one year of storage at 30°C. The solid thick line ($n=1$) indicates a velocity profile for a Newtonian fluid.

Alveograph and farinograph

Alveograph curves are commonly characterised by four parameters: resistance of dough to extension, known as tenacity (P , $1.1 \times$ maximum height of curve), extensibility of the dough (L , the length of the curve), P/L , a measure of the balance between resistance to extension and extensibility, and the total work needed to cause the dough to rupture (W , computed from the area under the curve) (Rasper 1980). The alveograph is quite sensitive to flour maturation (protein oxidation) and is also sensitive to quality deterioration in storage. The changes in the four parameters of the compacted and loose flour of both grades stored for 1 year at 20, 30, and 40°C are shown in Table III. The results indicate that the main factor was temperature. The doughs from all flours stored at 40°C were so inextensible that the curve went off-scale and the alveograph parameters could not be measured. With increasing storage temperature, dough became less extensible. This was an expected storage effect due to oxidation. Even at the 20°C storage temperature, the effects of oxidation over time were evident from higher P/L values. Both flours (75% and 83% extraction rate) became more tenacious and less extensible after storing at 20 and 30°C for a year. The extensibility of the 75% extraction rate loose flour was affected to a greater extent at 30°C than at 20°C, but its strength as related to W was not affected.

With the exception of the 83% extraction compacted flour stored at 20°C, which showed less evidence of oxidation than

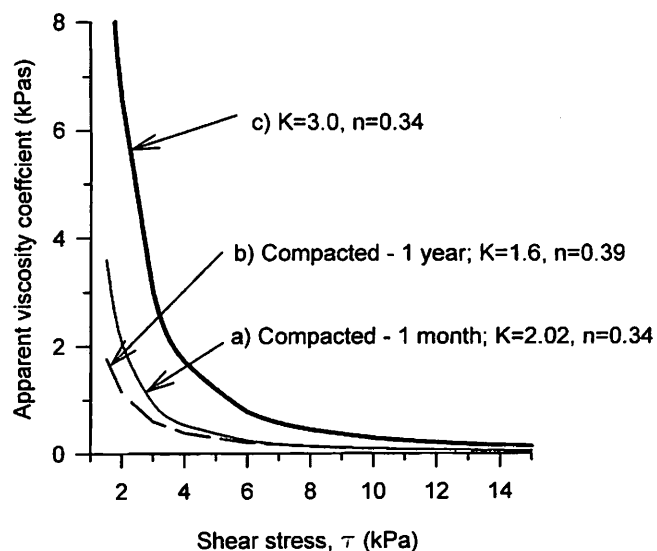

Fig. 7. Changes in the apparent viscosity coefficient as affected by the shear stress. The plots were developed for a) the 83% extraction compacted flour stored for a month at 30°C ($K=2.02$, $n=0.34$), b) for the same flour as above but after 12 months of storage ($K=1.6$, $n=0.39$) and c) for a hypothetical situation when the K coefficient (as in case a, the fine line) would increase to $K=3$.

the other flours, extraction rate appeared to have little effect on the pattern of change observed in alveograph curves. There was evidence that compaction caused a moderate decrease in oxidation during storage, as evident from lower P/L values for compacted flours stored at 20 and 30°C.

The farinograph curves are commonly characterised by water absorption, dough development time, dough stability, and dough mixing tolerance index. Water absorption is determined by titrating water into the dough to obtain a curve that at maximum consistency is centred at 500 Brabender Units (BU). Dough development time is the time to reach maximum consistency, while dough stability is a measure of the time interval between when the top of the curve reaches 500 BU and the time when the top of the curve falls below 500 BU. The dough mixing tolerance index is the drop in consistency of the midpoint of the curve 5 min after development time (Pylar 1988). Indications of stronger dough properties are longer development time, longer stability, and lower mixing tolerance index.

Farinogram parameters for compacted and loose flour of both grades as affected by storage temperature and storage time are shown in Table IV. In agreement with the alveograph results, storage temperature had a strong influence on dough properties, and the effect of compaction and extraction rate were minimal. Raising storage temperature from 20 to 30°C generally showed evidence of stronger dough properties. The big effect of temperature was at 40°C, where dough strength was considerably stronger than when it was stored at lower temperatures, evident from much longer development time and stability. Also, water absorption increased substantially for all flour samples kept at the 40°C storage temperature. Mixing

Table III. Alveograph properties for compacted and loose flour of both grades stored at three different temperatures for one year.

Duration of storage	Extract yield (%)	Storage temperature (°C)	Treatment of flour	Resistance P (mm)	Extensibility L (mm)	Ratio P/L	Total work, W (10 ⁴ J)
prior to storage	75	control	n/a	75	177	0.42	385
	83			64	153	0.48	246
End of 1 year storage	75	20	loose	111	106	1.04	438
	75		compacted	109	107	1.02	432
	83	loose	102	96	1.06	332	
	83	compacted	86	130	0.66	321	
	75	30	loose	130	92	1.41	441
	75		compacted	115	104	1.10	432
83	loose		125	93	1.34	382	
83	compacted	116	97	1.20	377		
	75	40	loose				
	75		compacted	off scale	off scale	n/a	off scale
	83		loose				
	83		compacted				

tolerance index was only moderately less at 40°C because the values at lower temperatures were already very low. This effect of storage temperature was in agreement with the capillary extrusion test results where the flow behaviour index was noticeably affected (Fig. 5a and 5c).

High storage temperatures (>30°C) are common in tropical countries throughout the year and during the summer in many countries with a continental climate. Changes in flour functionality due to high temperature can be a problem. Based

on the alveograph and farinograph results, it appears that extended storage up to 30°C is not necessarily detrimental to dough functionality, although rheological parameters change. The longer mixing time and stability associated with storage up to 30°C would be an asset in rigorous baking procedures featuring long fermentation times because fermentation tolerance would be greater. However, mixing time (and associated energy input requirements) would be considerably greater, which could pose a problem in bakeries using high

Table IV. Results of the farinograph tests for the loose and compacted flour before and after one year of storage at three different temperatures 20, 30, and 40°C.

Duration of storage	Extract yield (%)	Storage temperature (°C)	Treatment of flour	Absorption (%)	DDT* (min)	Stability (min)	MTI** (BU)
Prior to storage	75	n/a	n/a	61.8	6.25	8.0	40
	83			63.0	4.25	6.0	40
End of 1 year storage	75	20	loose	62.8	8.25	14.5	25
	75		compacted	63.0	7.5	14.5	20
	83	loose	64.0	7.0	11.0	30	
	83	compacted	63.8	6.25	11.0	30	
	75	30	loose	62.4	8.25	14.0	20
	75		compacted	63.0	7.25	14.5	20
83	loose		64.4	6.5	11.5	30	
83	compacted	63.8	7.0	13.0	20		
	75	40	loose	65.0	9.0	19.5	20
	75		compacted	65.2	10.0	19.5	10
	83		loose	66.8	6.75	12.5	20
	83		compacted	65.8	7.25	16.0	20

* DDT = Dough development time

** MTI (BU) = Mixing tolerance index, Brabender units

speed mixers and a no-time dough process. To maintain full production in typical no-time dough plants, dough must be developed within very narrow time limits, and the amount of energy that can be put into the dough in a given time period is limited. If mixing time is extended, less dough can be processed; if energy input during mixing is not sufficient the dough will be underdeveloped and dough handling properties and bread quality will deteriorate. In contrast, based on our alveograph experimental data, flour stored at 40°C would cause problems for bakers regardless of baking procedure. Dough became very “bucky” or inextensible (high P/L values) indicative of poor sheeting properties. Bucky doughs are difficult to sheet, an essential part of the moulding stage, and very tight dough might limit oven response and reduce loaf volume.

CONCLUSIONS

Compaction of 75% extraction rate flour to a 55% volume reduction had a marked effect on the magnitude of the flow behaviour index (n). This effect was not observed in 83% extraction rate flour. Increasing storage temperature caused the flow behaviour index to decline even after 1 month of storage for 75% extraction rate flour but not for 83% extraction rate flour. The storage time accounted for an increase in n values by 5 to 15%.

After 1 year of storage, the consistency coefficient, K, decreased for compacted flour at both extraction rates by 10 to 30% depending on the storage temperature. K of 75% extraction rate loose flour increased on average by 15% after 1 year of storage. K did not change for 83% extraction rate loose flour stored at 20 and 30°C, but decreased over 1 year by almost half when stored at 40°C.

Alveograph results indicated that the main factor affecting the oxidation of compacted and loose flour during storage was storage temperature. Flour stored at 40°C would cause problems for bakers. Compaction of flour to the 55% volume reduction appeared to have a moderate effect on changes in alveograph parameters during storage. The compacted samples used in our study were small with a relatively high relative area that would permit more rapid migration of water and diffusion of air than for larger commercial scale samples. The farinograph results were in general agreement with the alveograph results. Storage of flour up to 30°C resulted in moderate strengthening of dough properties as indicated by longer dough development time and longer stability, which could be an asset for rigorous (long fermentation) baking processes. Storage at 40°C had a much bigger effect on dough strength, consistent with alveograph data. The effect of storage temperature was confirmed by the capillary extrusion tests where the flow behaviour index was noticeably affected.

ACKNOWLEDGEMENT

The authors acknowledge the Natural Sciences and Engineering Research Council of Canada for providing financial assistance for conducting this research.

REFERENCES

- AACC. 1995. Methods:08-01; 44-15A; 46-12; 54-21. *Approved Methods of the American Association of Cereal Chemists*. St. Paul, MN: American Association of Cereal Chemists.
- Bell, B.M., N. Chamberlain, T.H. Collins, D.G.H. Daniels and N. Fisher. 1979. The composition, rheological properties and breadmaking behaviour of stored flour. *Journal of the Science of Food and Agriculture* 30:1111-1122.
- Bloksma, A.H. 1990. Dough structure, dough rheology, and baking quality. *Cereal Foods World* 35:237-244.
- Bushuk, W. 1985. Rheology: Theory and application to wheat flour doughs. In *Rheology of Wheat Products*, ed. H. Faridi, 1-26. St. Paul, MN: American Association of Cereal Chemists.
- Cenkowski, S., S. Ramanathan, M.G. Scanlon and J.E. Dexter. 1998. Thermodynamic and functional properties of mechanically compacted flour. *Canadian Agricultural Engineering* 40:35-45.
- Cuendet, L.S., E. Larson, C.G. Norris and W.F. Geddes. 1954. The influence of moisture content and other factors of the stability of wheat flours at 37.8°C. *Cereal Chemistry* 31:362-389.
- Faubion, J.M. and R.C. Hosney. 1989. The visco-elastic properties of wheat flour dough. In *Dough Rheology and Baked Product Texture*, ed. H. Faridi and J.M. Faubion, 29-66. New York, NY: Van Nostrand Reinhold.
- Hibberd, G.E. and N.S. Parker. 1975. Measurement of the fundamental rheological properties of wheat flour doughs. *Cereal Chemistry* 25:146-150.
- Hlynka, I. and J.A. Anderson. 1955. Laboratory dough mixer with an air-tight bowl. *Cereal Chemistry* 32:83-86.
- Hosney, R.C. 1985. Rheology and fermenting dough. In *Rheology of Wheat Products*, ed. H. Faridi, 177-191. St. Paul, MN: American Association of Cereal Chemists.
- ICC. 1980. Standard No. 107 (Falling Number); Standard No. 121 (Alveograph). *Standard Methods of the ICC, International Association for Cereal Science and Technology*. Vienna, Austria: International Association for Cereal Science and Technology.
- Kent, N.L. 1983. *Technology of Cereals*. Toronto, ON: Pergamon Press.
- Kleinbaum, D.G., L.L. Kupper and K.E. Muller. 1988. *Applied Regression Analysis and Other Multivariable Methods*. Boston, MA: PWS-KENT.
- Labuza, T.P. and C.R. Hyman. 1998. Moisture migration and control in multi-domain foods. *Trends in Food Science & Technology* 9:47-55.
- Loh, J. 1985. Rheology of soft wheat products. In *Rheology of Wheat Products*, ed. H. Faridi, 151-176. St. Paul, MN: American Association of Cereal Chemists.
- Menjivar, J.A. 1989. Fundamental aspects of dough rheology. In *Dough Rheology and Baked Product Texture*, ed. H. Faridi and J.M. Faubion, 1-28. New York, NY: Van Nostrand Reinhold.
- Mohsenin, N.N. 1986. *Physical Properties of Plant and Animal Materials*. New York, NY: Gordon and Breach.

- Pyler, E.J. 1988. *Baking Science and Technology*. Merriam, KS: Sosland Publishing.
- Preston, K.R. and J.E. Dexter. 1994. Canadian short process bread: Potassium bromate response of flour streams and divide flours milled from Canadian red spring wheat. *Canadian Journal of Plant Science* 74:71-78.
- Rasper, V.F. 1980. Theoretical aspects of amylography. In *The Amylograph Handbook*, ed. W.C. Shuey and K.H. Tipples, 1-6. St. Paul, MN: American Association of Cereal Chemists.
- Steffe, J.F. 1992. *Rheological Methods in Food Process Engineering*. East Lansing, MI: Freeman Press.
- Tsen, C.C. and C.J. Dempster. 1963. Changes in sulfhydryl groups of flour during storage. *Cereal Chemistry* 40:586-589.
- Warwick, M.J., W.H.H. Farrington and G. Shearer. 1979. Changes in total fatty acids and individual lipid classes on prolonged storage of wheat flour. *Journal of the Science of Food and Agriculture* 30:1131-1138.
- Wolter, K. 1986. Flour quality - flour storage - flour temperature (German). *Allgemeine-Baecker-Zeitung* 41:3-4, 6.
- Yoneyama, T., I. Suzuki and M. Murohashi. 1970. Natural maturing of wheat flour. I. Changes in some chemical components and in farinograph and extensigraph properties. *Cereal Chemistry* 47:19-26.