

---

# Effect of load fixture design on sensitivity of an extended octagonal ring (EOR) transducer

N.B. McLaughlin<sup>1\*</sup>, B.S. Patterson<sup>1</sup> and S.D. Burt<sup>1</sup>

<sup>1</sup>*Eastern Cereal and Oilseed Research Centre, Research Branch, Agriculture and Agri-Food Canada, 960 Carling Ave., Ottawa, ON K1A 0C6 Canada*

*\*Email: neil.mclaughlin@agr.gc.ca*

---

McLaughlin, N.B., B.S. Patterson and S.D. Burt. 2012. **Effect of load fixture design on sensitivity of an extended octagonal ring (EOR) transducer.** Canadian Biosystems Engineering/Le génie des biosystèmes au Canada **54**: 2.17-2.22. Identical loading and support fixtures were fabricated to apply vertical compressive loads at two points with varying spacing on the faces of an Extended Octagonal Ring (EOR) transducer. A calibration apparatus employing an air cylinder fitted with a strain gage load cell was assembled to apply and measure vertical load on the EOR. Calibrations were performed to determine the effect of spacing between the two loading points on EOR sensitivity. At moderate load point spacings, a small decrease in EOR sensitivity was noted with increasing load point spacing. The EOR sensitivity rapidly decreased as the load points approached the ring sections, with approximately 40% reduction in sensitivity when the load points were near the sloped outer surface of the ring sections. Effect of non-flat loading and support fixtures was evaluated by calibrating the EOR with different torques applied to the mounting bolts and with varying load point spacings. Tension in the mounting bolts created an initial bending moment in the EOR at zero applied load. Bolt torque had little effect on EOR sensitivity at small load point spacings, but high bolt torque decreased the EOR sensitivity at large load point spacings. When the loading points were over the ring sections, the changing the bolt torque from zero to maximum changed the EOR offset (zero load signal) by an amount approximately equal to the EOR design capacity. These results demonstrate the importance of careful attention design of the load and support fixtures and calibration procedures for an EOR to achieve optimum performance. **Key words:** EOR, EORT, extended octagonal ring, extended octagonal ring transducer, extended ring transducer.

Des dispositifs identiques de support et de chargement ont été fabriqués dans le but d'appliquer des forces verticales de compression à deux emplacements sur les facettes d'un dispositif de mesure des forces de type anneau octogonal élargi (EOR). Ces dispositifs permettaient de varier l'espacement entre les deux points où les charges étaient appliquées. Un outil de calibration employant un vérin pneumatique et équipé de jauges extensométriques a été assemblé pour appliquer et mesurer les charges verticales sur le EOR. Une calibration a été complétée pour déterminer l'effet de l'espacement entre les deux points de chargement sur la sensibilité du EOR. Pour de faibles valeurs d'espacement, une légère diminution de la sensibilité du EOR a été notée avec une augmentation de l'espacement entre les points d'application de la charge. La sensibilité du EOR a diminué rapidement au fur et à mesure qu'approchaient les sections de

l'anneau, avec une réduction approximative de 40% de la sensibilité lorsque les points d'application de la charge se situaient près de la surface inclinée extérieure des sections de l'anneau. L'effet de la géométrie non plane des attaches de support a été évalué en calibrant l'EOR avec différents couples de serrage appliqués sur les boulons de montage et avec des espacements variables des points de chargement. La tension appliquée aux boulons de montage créait un couple de torsion initial dans le EOR pour une charge appliquée nulle. Le couple de serrage des boulons avait peu d'effet sur la sensibilité du EOR pour des petits espacements des points de chargement tandis qu'un couple de serrage élevé diminuait la sensibilité du EOR pour de grands espacements des points de chargement. Lorsque les points de chargement étaient au-dessus des sections annulaires, une augmentation du couple de serrage des boulons de zéro à la valeur maximale changeait la lecture de base du EOR (signal de charge nulle) par une valeur approximativement égale à la capacité de mesure du EOR. Ces résultats démontrent toute l'importance d'une attention particulière lors de la conception des dispositifs de chargement et de support de même qu'aux procédures de calibration pour l'atteinte d'une performance optimale par les dispositifs EOR. **Mots clés:** EOR, EORT, anneau octogonal élargi, transmetteur d'anneau octogonal élargi, transmetteur d'anneau élargi

## INTRODUCTION

The extended octagonal ring (EOR) transducer is a popular device for measurement of forces and moments in agricultural engineering research. The EOR is a variation on the familiar proving ring, which has been in use for many decades. The EOR features a massive central section, with thin ring sections at either end (Fig. 1). The thick central section allows for a variety of design options for support and loading fixtures for the EOR. Strain gages installed on the thin ring sections allow measurement of bending moments in the rings, which can be transformed into forces and moments, applied to the transducer. The gages are normally located at strain nodes, and connected into separate bridges so that the forces and moments can be measured independent from each other, and with minimal cross sensitivity (Fig. 1).

Design of an EOR for a specific application requires knowledge of stress and strain distribution in the ring sections so that the device dimensions and strain gage locations can be chosen to maximize overall sensitivity, and minimize cross sensitivity among the different

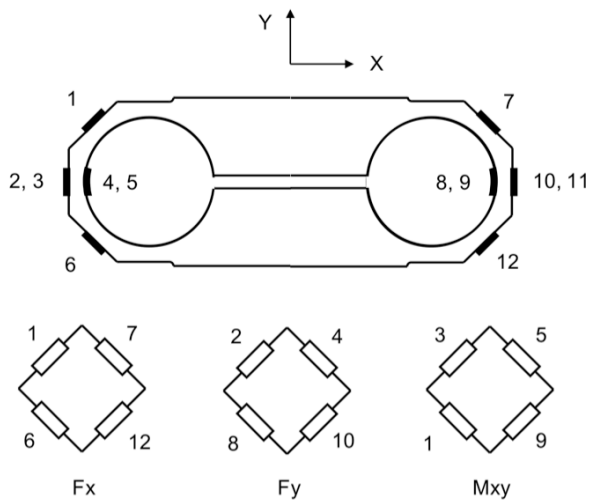

**Fig. 1 Extended Octagonal Ring Transducer with location of strain gages and strain gage bridge arrangement for independent measurement of vertical force, horizontal force, and applied moment.**

channels. Hoag and Yoerger (1975) derived an elegant set of analytical equations based on classical mechanics for the bending moment distribution in the ring sections of a plain extended ring transducer. McLaughlin (1996) discovered some typographical errors in one of the equations, and presented the corrected equations. The plain extended ring transducer is similar to the EOR except that both the inner and outer faces of the ring sections are circular providing a uniform ring thickness. The varying ring thickness of the EOR creates a very complex distribution of ring stresses, and analytical equations describing the ring stresses have not been developed. Many researchers use the Hoag and Yoerger (1975) equations for the extended ring transducer with uniform ring thickness as a first approximation in designing an EOR (McLaughlin et al. 1998). Other approaches to analysis of strain distribution in the EOR include strain gage arrays (Godwin 1975), photo elastic strain analysis (Cook and Rabinowicz 1963; Pang et al. 1988), and more recently, finite element stress analysis (Majumdar et al. 1994).

The Hoag and Yoerger (1975) equations are based on the assumption that the central section of the extended ring transducer ( $x < \pm L$  in Fig. 2) is sufficiently stiff that deformation can be neglected, and therefore, the slopes of the ring sections at either end of the central section ( $x = \pm L$ ,  $\phi = \pm \pi/2$ ) are equal, and are zero for both vertical or horizontal loading. If this assumption is valid, then the sensitivity of the device should be independent of the distribution of the applied load along the face of the transducer; the sensitivity should be the same for load applied at a single point in the centre of the device, at two or more arbitrarily spaced points, or distributed (uniformly or otherwise) along the EOR face. It is generally assumed that the central section is sufficiently stiff that the

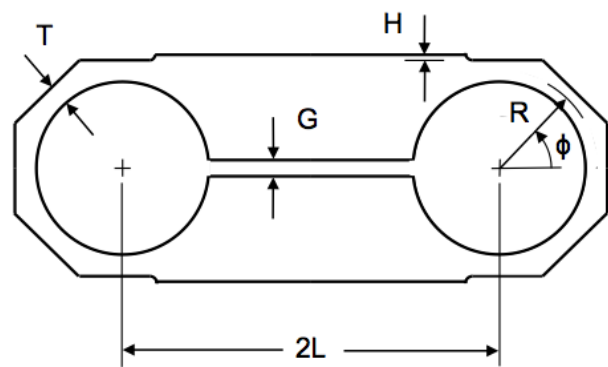

**Fig. 2 Dimensions of the EOR used in the loading experiments:  $L = 80$  mm,  $R = 36$  mm,  $T = 8$  mm,  $H = 2$  mm,  $G = 4$  mm. The EOR width was 90.3 mm.**

arrangement for applying the load and for mounting the EOR to supply reaction forces is unimportant. Often, the loading fixtures are simply bolted to the central section.

Godwin (1975) noted that when the load fixture touched the ring sections, the position of the strain node for vertical force was altered. He recommended that the length of the load fixture be less than  $2(L-R)$  (Fig. 2). Godwin (1975) used a thin shim plate with length less than  $2(L-R)$  to provide clearance between a long load fixture and the ring section. In a later design, he used a raised boss on the central section to provide this clearance.

Load cell manufacturers recognize the importance of mounting configuration. One manufacturer stated that for their line of low profile load cells, the loading fixture must be at least two or three times as rigid as the load cell, must have a surface flat to within  $25 \mu\text{m}$ , and have a minimum hardness of Rockwell B-100 (Strainsert 2011). Presumably, loading fixtures with these specifications will apply minimal extraneous distortion of the load cells when mounting bolts are tightened and when loads are applied. It is likely that the load cell manufacturers are conservative and stress proper mounting to optimize performance of their product. However, they do not quantify in their literature the extent to which performance will be degraded with improper mounting.

This paper presents data on the effect of location of the points of load application on the sensitivity of an EOR. The objective is to demonstrate that design of the loading or support fixtures can have a substantial effect on the sensitivity of an EOR.

## MATERIALS AND METHODS

Experimental measurements were made on an EOR on loan from Agriculture and Agri-Food Canada research centre in Charlottetown, PE. The National Institute of Agricultural Engineering, Silsoe, UK, originally fabricated the EOR. The EOR material was steel, and dimensions are given in Fig. 2. The EOR had a raised boss on each loading face to provide clearance between an extended load fixture and the ring sections as recommended by Godwin (1975). Eight

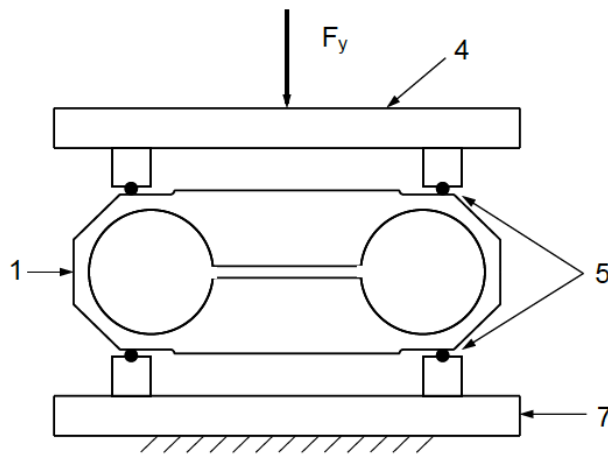

**Fig. 3. Diagram of the test apparatus with support and loading fixtures. Screw mechanism for changing the spacing of the loading points is not shown. Labels are defined in the caption for Fig. 4.**

mounting bolt holes were drilled and tapped for M12 x 1.75 bolts on each loading face; only four mounting bolts were used in each face in the present experiment.

#### **Loading and support fixtures**

Loading and support fixtures were devised for the EOR where compressive vertical loads could be applied at two points separated by varying distance along the loading face. The support and loading fixtures were identical, and each consisted of a 25 mm thick steel plate with a pair of moveable loading contact points (Figs. 3 and 4). The support fixture was attached to a rigid steel reaction frame and the EOR was sandwiched between the support and loading fixtures. The EOR was attached to the loading and support fixtures via four bolts screwed into the tapped holes on the faces of the EOR.

Each loading “point” consisted of a 4.5 mm dia. rod supported and cemented into a groove milled in a 25 mm square steel block (Figs. 3 and 4). The 4.5 mm dia. rod contacted the EOR loading face along the entire width of the EOR, and approximated point loading in the x-y plane. The 25 mm square block and rod assemblies could be moved along the loading face by a screw thread system to achieve different spacing between the two loading points.

#### **Calibration apparatus and procedure**

Calibrations were done to determine the sensitivity of the EOR with different spacings between the contact points on the loading and support fixtures. Vertical load was applied to the centre of the loading fixture via an air cylinder fitted with an 11 kN strain gage load cell (Fig. 4). Air was supplied from the laboratory compressed air system via a regulator. A needle valve was used to throttle the air flow to the cylinder to gradually apply vertical load from zero to maximum of 5.0 kN over an approximately 30 second interval, and to release the load at

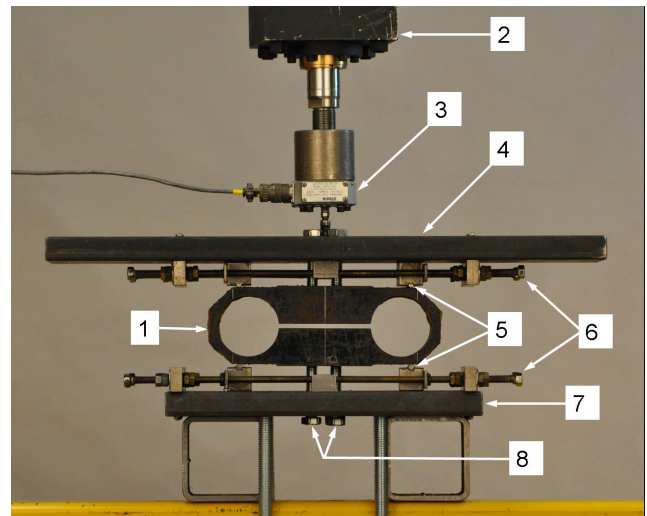
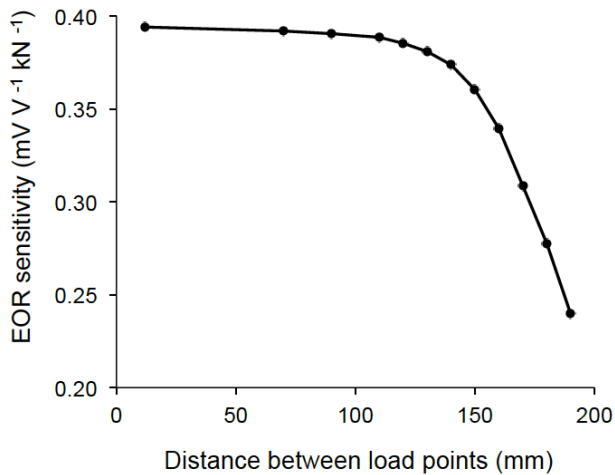

**Fig. 4. Apparatus for applying load at different points along the surface of the EOR. 1) EOR. 2) Air cylinder for applying vertical load. 3) Strain gage load cell. 4) Loading plate. 5) Loading and reaction points. 6) Screw mechanism for adjusting spacing between loading points. 7) Support plate to provide reaction forces. 8) EOR mounting bolts (four on each face of the EOR, loosened except for bolt torque test).**

approximately the same rate. Horizontal load or moment in the x-y plane was not applied. A data logger was used to excite strain gage bridges on the EOR and the air cylinder load cell, and record their respective signals. Excitation voltage was set at 5.0 volts for the strain gage bridges in the EOR, and at 10.0 volts for the load cell strain gage bridge. A lower excitation voltage was used for the EOR than the load cell to reduce thermal effects from self heating of strain gages in the EOR; the EOR had 120 ohm strain gages while the load cell had 350 ohm strain gages. Strain gage bridge signals on the load cell and EOR were logged continuously at 100 Hz for three cycles of vertical load application and release from zero to maximum applied with the air cylinder.

A zero or tare file was logged before and after the calibration measurements for each configuration of the loading fixture. The air cylinder was retracted so that there was no contact between the air cylinder load cell and the EOR loading fixture and the zero file was logged with zero applied load. No-load data from these zero files provided a means to monitor and correct for any change in offset of the strain gage bridges on the load cell and EOR due to instrumentation drift. Small changes or drift in offset are inevitable, particularly on the EOR where temperature-compensating devices were not installed.

Calibrations were conducted for spacings between the loading points ranging from 12 mm to 190 mm. Symmetry was preserved for all calibrations; the two loading points were always equidistant from the EOR centre, and the



**Fig. 5. EOR sensitivity vs. distance between load points for loosened mounting bolts.**

same spacing between the loading points was used for both the loading and support fixtures.

The calibrations were conducted both for the mounting bolts loosened, and over a range of bolt torques from zero to 135 N m. In the loosened condition, the bolts ensured alignment between the EOR and the loading and support fixtures, but did not transmit any vertical load. In the torqued condition, the bolts placed an initial bending moment on both the loading and support fixtures, and the EOR central section simulating warped loading and support fixtures. Initial bolt torque deforms the central section, which changes the moment distribution in the ring sections.

**Data analysis**

Each measurement was corrected for drift in the offset by subtracting the weighted average of the apparent load calculated from the zero files logged for zero applied load before and after the calibration test. Drift was assumed to be linear with time, and the offset from the before and after zero load was weighted in proportion to the elapsed time between each measurement and the respective before and after zero files. Sensitivity was calculated by linear regression between the corrected bridge outputs of the load cell (independent variable), and EOR bridge (dependent variable). The sensitivity was normalized to milli-volts output per volt bridge excitation per kilo Newton applied vertical load (mV V<sup>-1</sup> kN<sup>-1</sup>).

**RESULTS**

**Effect load point spacing on EOR sensitivity**

The EOR sensitivity is plotted against spacing between the loading (and support) points in Fig. 5. The mounting bolts were loosened for this set of calibrations and did not transmit any vertical load. A gradual decrease in sensitivity was evident for increasing spacing between the loading points up about 100 mm, which corresponds to loading at either end of the raised boss. Although the

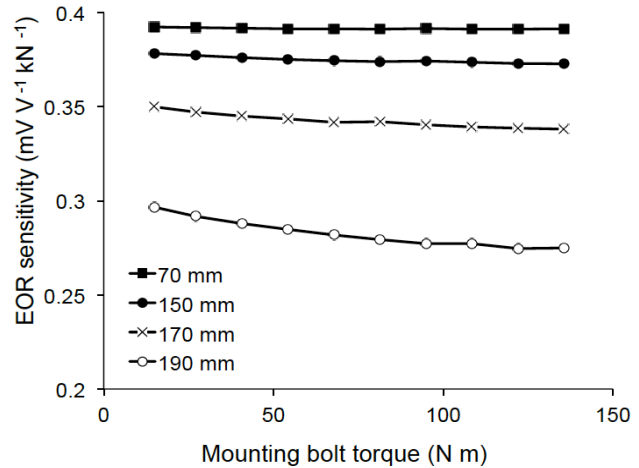

**Fig. 6. EOR sensitivity vs. mounting bolt torque at load point spacings of 70, 150, 170 and 190 mm.**

change in sensitivity in this region was small (about 1 to 2%), it is clearly evident in Fig. 5. The EOR sensitivity declined rapidly with increasing spacing between the loading points beyond the raised boss. In the extreme case where the loading points were near the sloped outer face of the ring section (load point spacing = 190 mm) the EOR sensitivity was only about 60% of that when the load was applied near the centre of the EOR.

**Effect of bolt torque on EOR sensitivity and offset**

The effect of bolt torque on EOR sensitivity at different spacings between the loading points is shown in Fig. 6. When the load point spacing was 70 mm, the curve of sensitivity vs. bolt torque was nearly flat indicating minimum effect of bolt torque. Load point spacings less than 70 mm yielded similar results (data not shown). There was a trend for decreasing slope (becoming more negative) of the EOR sensitivity vs. bolt torque curve with increasing load point spacing. At a load point spacing of 190 mm (load points near the sloped outer face of the ring sections), the decrease in EOR sensitivity caused by increasing bolt torque from 15 to 135 N m was 7.3%.

The effect of bolt torque on the EOR vertical bridge offset is given in Fig. 7. With the load points spaced at 180 mm, the offset changed by 1.4 mV V<sup>-1</sup> when the bolt torques were increased from 15 to 135 N m. At a nominal sensitivity of 0.39 mV V<sup>-1</sup> kN<sup>-1</sup>, the change in offset of 1.4 mV V<sup>-1</sup> corresponds to an apparent applied load of 3.59 kN, about 72% of the 5.0 kN loading range used in the calibrations.

**DISCUSSION**

The change in sensitivity with increasing space between the loading points, and with increasing torque on the bolts was believed to be due to differential distortion by bending of the central section of the EOR. The amount of distortion accompanying a given load is a function bending moment on the central section, which in turn is a



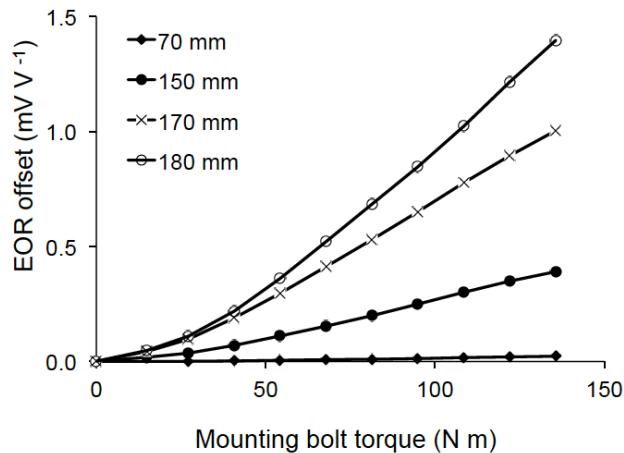

**Fig. 7. EOR offset vs. mounting bolt torque at load point spacings of 70, 150, 170 and 180 mm.**

function of spacing of the loading points, stiffness of the loading plate, and tension in the bolts. Distortion of the central section causes a change in slope of the ring sections at either end, i.e.  $\phi = \pi/2$  for the top half (same angle at both ends), and  $\phi = -\pi/2$  for the bottom half. This shifts the distribution of strain in the ring section and results in a change in strain at the gage locations for a given load, and consequently, a change in EOR sensitivity.

The Hoag and Yoerger (1975) equations are based on the assumption that the central section is sufficiently stiff that deformation can be neglected and the slope of the ring sections at  $\phi = \pm\pi/2$  is the same at either end. Under this assumption, there should be no change in sensitivity for loading at two points at any spacing less than  $2L$  (Fig. 2). However, Fig. 5 shows that the EOR sensitivity for load point spacing of 160 mm ( $2L$ ), is about 86 % of that for a load point spacing of 12 mm. The Hoag and Yoerger (1975) equations do not place restrictions on the loading configuration; these equations would predict exactly the same sensitivity for the extended ring transducer for vertical loading at a single point, at multiple points, or distributed along the face of the extended ring transducer. The change in sensitivity with different load point spacings was believed to be due to differences in distortion of the central section by bending under different load point spacings or bolt torques, which would create different, slopes of the ring sections at either end (i.e.  $\phi = \pm\pi/2$ ). This violates the Hoag and Yoerger (1975) assumption of equal ring slopes. A non-zero ring slope at  $\phi = \pm\pi/2$  changes the strain distribution in the rings, and consequently, changes the EOR sensitivity. The present data are for an extended octagonal ring while the Hoag and Yoerger (1975) equations are for a plain extended ring with circular inner and outer ring surfaces and constant ring thickness. While the difference in ring design will likely result in differences in numeric value for the change in sensitivity, it is likely that the trends will be similar for the EOR and extended ring transducer.

Some authors have reported discrepancies between the Hoag and Yoerger (1975) equations and experimental results on an EOR with varying ring thickness (Leonard 1980; McLaughlin et al. 1998). It was generally assumed that the discrepancy was due to varying ring thickness of the EOR whereas the Hoag and Yoerger equations were derived for a plain extended ring transducer with constant ring thickness. The present results suggest that the discrepancy may be partly due to neglecting deformation of the central section leading to an invalid assumption of equal ring slopes at either end of the transducer. A more thorough investigation with finite element analysis is required to provide more insight into the apparent discrepancy.

Godwin (1975) noted a shift in the location of the strain node if the loading fixture touched the ring section, and recommended that the load fixture length be less than  $2(L-R)$  to ensure that there was no contact with the ring section. Following this recommendation would eliminate the potential for the substantial 40% drop in sensitivity noted with a load point spacing of 190 mm which is greater than  $2L$  (160 mm). However, following the recommendation does not completely solve the problem because the sensitivity for load point spacing of 88 mm (44 mm or  $L-R$  on either side of the EOR centre) is approximately 1% lower than a load point spacing of 12 mm (Fig. 5). The present EOR was designed by the Dr. Godwin, and has a raised boss extending 48 mm on either side of the EOR centre to provide clearance between a long loading fixture and the ring sections.

#### Effect of mounting bolt torque

Torque on the mounting bolts creates tension in the bolts, and applies a bending moment to both the loading plate and the EOR central section creating some distortion in all of the loading plate, EOR central section, and EOR ring sections. When the air cylinder applies a compressive load in the centre of the loading plate, the loading plate is further distorted causing an interaction between the load and bolt tension. When the loading points are outside the mounting bolts, the bending moment applied by bolt tension to the EOR central section is in the opposite direction to the bending moment applied to the central section by vertical loading at the two load points. Consequently, the interaction between bolt torque and load point spacing results in a further reduction in EOR sensitivity, particularly at the larger load point spacings. This is clearly evident in Fig. 6 as decreased slope (more negative) of the sensitivity vs. bolt torque curve with greater load point spacings.

Tension in the mounting bolts resulting from initial bolt torque created an offset in the EOR at zero applied load, particularly at large load point spacings (Fig. 7). This was believed to be due to distortion in the EOR central and ring sections caused by the bending moment applied by bolt tension. Fortunately, balancing the strain gage bridges at zero-load when the EOR is installed, and the mounting bolts are torqued to specification can often

accommodate the offset. However, there are some applications where this is impractical or impossible. In these cases, the change in offset with bolt torque cannot be distinguished from an applied load, and only the changes in applied load can be measured with any degree of confidence; bridge voltage from the absolute applied load would be confounded with offset due to bolt torque.

To some extent, compensation for the effect of load fixture design on EOR sensitivity can be achieved by calibrating the EOR with the same load fixture and same conditions that will be used for subsequent measurements. While this is good practice, it may not always be feasible. Also, if the load fixture is warped, different combinations of load components (i.e. vertical, horizontal and moment) can change effective contact points, and therefore, alter the apparent EOR sensitivity.

#### **Generalization of the results**

The numerical results of the experiment are valid only for an EOR of the exact same dimensions. Different EOR dimensions and different strain gage locations would result in different influences of loading configuration on EOR sensitivity. Although similar trends would be expected, the findings in this paper should not be used to “correct” data from an EOR of different dimensions. The experimental results point out the importance of careful attention to design of the loading and support fixtures for optimal performance of an EOR. The results confirm the load cell manufacturers’ statements about the importance of flatness, stiffness, and surface finish of load cell mounting plates (Strainsert 2011).

#### **CONCLUSIONS**

An apparatus was developed to apply vertical loads at two points with varying spacing on the face of an Extended Octagonal Ring (EOR) transducer. Calibration showed a small decrease in EOR sensitivity as the loading points were moved from near the centre of the EOR towards the end of the thick central section. As the loading points approached the sloped outer part of the ring sections, the EOR sensitivity decreased by nearly 40%.

Torque in the mounting bolts applied an initial bending moment to the EOR central section. Mounting bolt torque had little effect on the EOR sensitivity for small load point spacings, but mounting bolt torque

decreased EOR sensitivity at the large load point spacings. Torque in the mounting bolts also created an initial offset at zero applied load.

The results point out the need for careful attention to the design of mounting and loading fixtures for optimum performance of an EOR. Ideally, the EOR should be calibrated in place with the loading and support fixtures installed, and bolts torqued to specification.

#### **ACKNOWLEDGMENTS**

Gratitude is extended to Dr. Allan Campbell, Charlottetown Research Centre for loan of the EOR, and to Mr. Alain Saumure and Mathew Kenny, ECORC engineering shop for fabrication of the loading apparatus.

#### **REFERENCES**

- Cook, N.H. and E. Rabinowicz. 1963. *Physical Measurement and Analysis*. Reading, MA: Addison-Wesley Publishers.
- Godwin, R.J. 1975. An extended octagonal ring transducer for use in tillage studies. *Journal of Agricultural Engineering Research* 20:347-352
- Hoag, D.L. and R.R. Yoerger. 1975. Analysis and design of load rings. *Transactions of the ASAE* 19:995-1000.
- Leonard, J.J. 1980. An extended-octagon rigid drawbar dynamometer. *Agricultural Engineering Australia* 9(1):3-8.
- Majumdar, S., E.V. Thomas and D.S. Jayas. 1994. Optimization of parameters in the design of an extended octagonal-ring transducer. *Agricultural Engineering Journal* 3(4):152-165.
- McLaughlin, N.B. 1996. Correction of an error in equations for extended ring transducers. *Transactions of the ASAE* 39(2):443-444.
- McLaughlin, N.B., S. Tessier and A. Guilbert. 1998. Improved double extended octagonal ring transducer for 3-D force measurement. *Canadian Agricultural Engineering* 40(4):257-264.
- Pang, S.N., G.C. Zoerb and B.A. Rostad. 1988. Application of photoelastic analysis of an extended octagonal ring. ASAE Paper NCR 88-105. St. Joseph, MI: ASABE.
- Strainsert. 2011. Standard load cell installation instructions. <http://www.strainsert.com/pages/load-cells-installation.php> (Accessed April 27, 2011).