



XVIIth World Congress of the International Commission of Agricultural and Biosystems Engineering (CIGR)

Hosted by the Canadian Society for Bioengineering (CSBE/SCGAB)
Québec City, Canada June 13-17, 2010



SIMULATION ON CREEP PROCESS OF ALFALFA BASED ON VIRTUAL PROTOTYPE

WANG CHUNGUANG¹, ZHAO GUIZHI², WANG ZHUO³

¹Wang Chunguang: Professor, Mechanical and electrical engineering college of Inner Mongolia agricultural university, hhhut city, Inner Mongolia, P.R.China wcgjdy@yahoo.com.cn

²Zhao Guizhi: Lecture, Mechanical and electrical engineering college of Inner Mongolia agricultural university, hhhut city, Inner Mongolia, P.R.China guizhi_84@yahoo.com.cn

³Wang Zhuo: student, Beijing Institute of technology, Beijing, P.R.China wzh0575@sina.com

CSBE100399 – Presented at the 8th World Congress on Computers in Agriculture (WCCA) Symposium

ABSTRACT Based on the ADAMS virtual prototype technology, a virtual prototype model of creep process of alfalfa compressed was established. Through comparing the simulation with experimental results, studying results showed that the creep model established is in accordance with the actual creep process of alfalfa compressed, the value of absolute error between simulation and experimental results was within ± 0.009 , and value of the relative error was within $\pm 1.55\%$.

Keywords: alfalfa, creep properties, virtual prototype, simulation

INTRODUCTION Agricultural fiber materials belong to viscoelastic materials. Studying the rheological properties of agricultural fiber materials is very difficult according to the rheological theory and experiment methods. Main reason is that providing a constant stress or a constant strain is almost imposible at a moment during compressing experiment for agricultural fiber materials, and a real experiment for stress relaxation or creep such rheological properties needs more time and more money, repeatability of experiment results is not good as well.

Virtual prototype technology based on ADAMS is a kind of new technology that mainly is used in mechanical system dynamics analysis. The stress relaxation or creep properties of forage, corn straw and alfalfa such agricultural fiber materials is often represented with a Generalized Maxwell model or a four elements Buges model. This laid the foundation for studying the rheological properties of agricultural fiber materials using ADAMS virtual prototype technology, at the same time, a constant stress or a constant strain can be accurately exerted on the virtual prototype in ADAMS.

Based on the virtual prototype technology, we established the virtual prototype models of creep process of alfalfa compressed. Through simulating creep process of alfalfa using the virtual prototype model, the creep property of alfalfa is discussed.

1. ADAMS model of the creep properties of alfalfa

The paper [1] finds that the creep process of alfalfa can be represented with a four elements Buges model, namely the series of a Maxwell model and a Kelvin model. As shown in Fig.1. In ADAMS software the spring and damper are given in parallel manner. Therefore, when the damping coefficient is equal to zero, the model will become pure spring, when the elastic coefficient is equal to zero, the model will become pure damper. So a pure spring or damper is established firstly in ADAMS, and then a Buges model will be made up by parallelling or seriesing ways. For determining creep model of alfalfa, the transient elastic, delay elasticity and viscosity coefficient of rheological parameters should be given. Using many factor experimental results, the transient elastic, delay elasticity and viscosity coefficient were obtained, the parameters obtained in table 1.

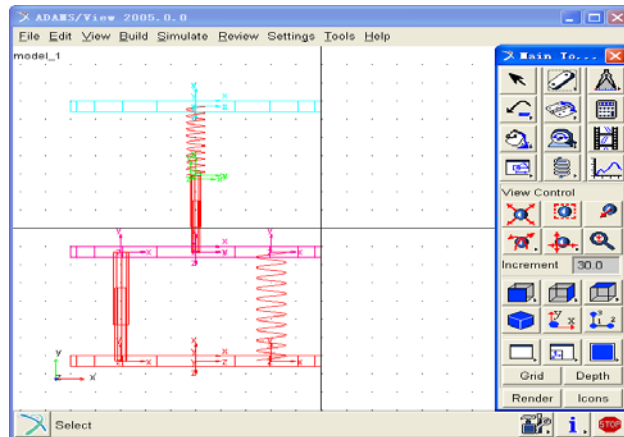
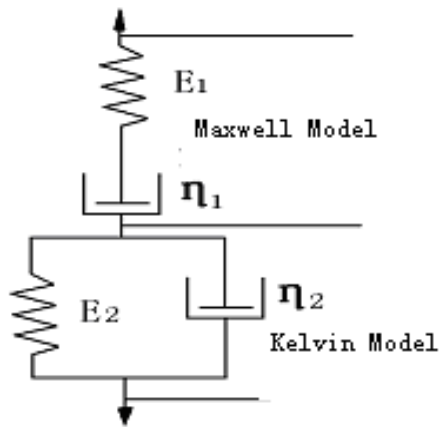

Fig. 1 creep model of alfalfa compressed

Fig.2 ADAMS model of alfalfa compressed

When the condition of moisture content, initial density and loading force are 22.5%, 45kg/m³ and 5500N respectively, the creep model of alfalfa compressed is as in Fig.2 by using of virtual prototype analysis based on ADAMS.

Table 1 parameter values in creep model with different initial density

initial density /kg/m ³	E_1 /N/mm ²	E_2 /N/mm ²	τ_s	η_1 /N · s/mm ²	η_2 /N · s/mm ²
25	1.499	16.882	0.009	77638.457	0.152
30	1.512	25.711	0.235	62574.535	6.042
35	1.479	37.175	0.196	54233.805	7.286
40	1.493	41.409	1.331	57824.845	55.115
45	1.471	64.505	0.241	30093.380	15.546

When creep properties of alfalfa are analyzed, the unit of stress is replaced by the appoved tacitly unit of force in ADAMS. The value of force is equal to the stress value. Creep is strain changing with time under a constant stress, which relate to only the elastic

modulus, viscosity coefficient, stress and time. But it doesn't relate to the mass of raw materials and gravity. Therefore, it is necessary to put parts the mass of elements as tiny enough and the situation with no gravity when the creep model is established using ADAMS virtual prototype technology. Thus those effects of mass and gravity can be avoided when creep properties of alfalfa is analyzed.

2. Adding constraint

The creep properties of alfalfa are strain changing with time when alfalfa is compressed under a constant stress condition. Therefore, volume of the creep model of alfalfa in ADAMS changes with time, namely in Fig. 3 the Part_2 using mobile pair, the Part_4 motionless, using fixed links and connecting with the earth (Part_1). The spring and damper in ADAMS model should be vertical movement during creep process of alfalfa, so Part_3 and

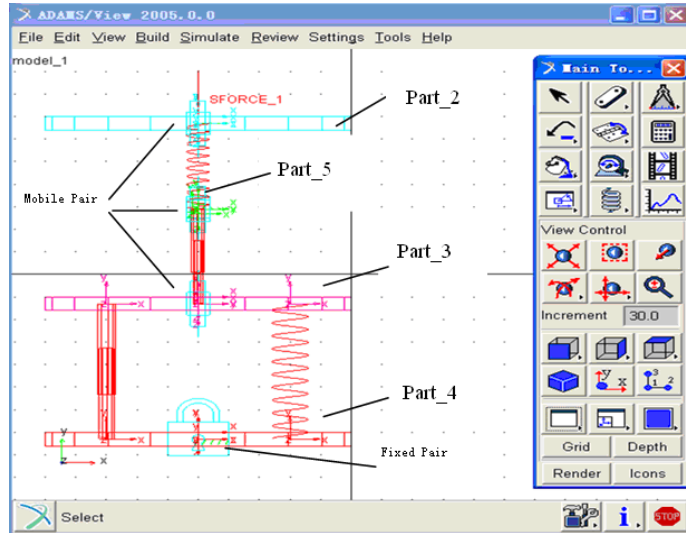

Fig.3 constraint of creep model of alfalfa

Part_5 are connected with a mobile pair. The constraint conditions added in creep model of alfalfa in ADAMS are shown in Fig.3.

3. Loading and ADAMS model self-inspection

In establishing the creep model of alfalfa in ADAMS, the most important step is to exert movement and load on the model established. The purpose of establishing creep model of alfalfa is to test the changing law strain with time. It is essential that a constant stress should be exerted on the creep model established in ADAMS firstly, and then the changing law of strain changing with time will be studied.

The self-inspection of ADAMS model is tested by self-inspection tool in ADAMS. The connection, constraint, the component constraint of the model, no quality components, freedom of prototyping, etc are test. The poupers of testing are the comprehensive evaluation for the model estanblished according to the mechanical principle. After the self-inspection simulation test can be carried out.

4. Comparing between simulation and experimental results

In ADAMS model, moisture, initial density and loading force are 22.5%, 45kg/m^3 and 5500N respectively when creep model of alfalfa in ADAMS is simulated for 100s and step 0.1 s. Simulation results are shown as in figure 4. When the simulation testing in ADAMS/ View is acomplished, then entering the model into ADAMS/PostProcessor post-processing module, and the experiment results obtained are put into the model, and

compared with the results of simulation, the accuracy of the creep model of alfalfa can be inspected furtherly. Comparing results is shown as in figure 5.

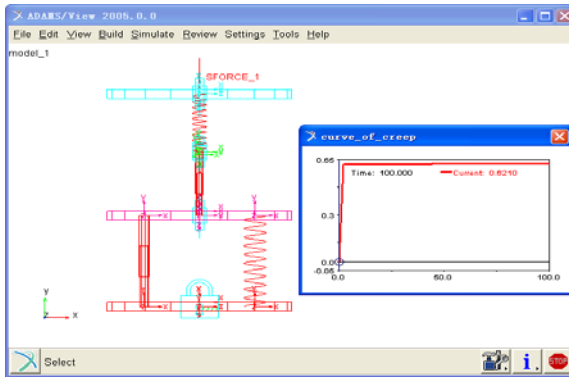

Fig.4 Simulation results of creep process of alfalfa

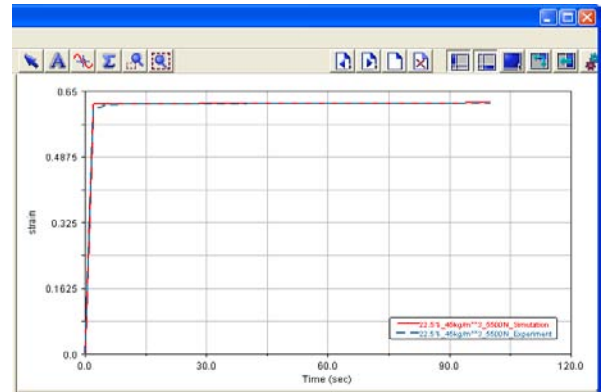

Fig.5 Comparing simulation results with experiment results

In Figure 5, the results of simulation show that simulation results have a good coincidence with experiment results, the absolute error is within ± 0.009 , and the relative error is within $\pm 1.55\%$.

CONCLUSION Based on virtual prototype technology in ADAMS, a virtual prototype model of creep process of alfalfa compressed was established. The simulation results approved that a constant stress can be exerted on alfalfa very easily in an instant, and the creep process of alfalfa can be seen during compressing process using virtual prototype model of alfalfa creep. Moreover, the simulation results shown that the results of simulation using virtual prototype model of alfalfa creep established accords with the actual creep process of alfalfa, the values of absolute error is within ± 0.009 , and the relative error is within $\pm 1.55\%$.

REFERENCES

1. Zhao GuiZhi. 2009..The experimental research and simulation for creep properties of alfalfa.. Master degree theses. Inner Mongolian: Inner Mongolian agricultural university, 14-36
2. Wang ChunGuang. 1998. The study on rheological properties for hay compressed in high density. Ph.D. Dissertation. Beijing: China agricultural university, 1 -33
3. Wang ChunGuang, TanLiDong. 2005..The study on hay compressed in high density based on virtual prototyping technology. [J] Transaction of the chinese society for agricultural machinery. 99~101
4. Tan LiDong. 2003.The computer analysis and simulation on hay compressing process in high density. Master degree theses. Inner Mongolian: Inner Mongolian agricultural university.11-14
5. Wang HongBo 2007.Virtual prototyping analysis on compressibility and stress relaxation properties for hay. Ph.D. Dissertation. Inner Mongolian: Inner Mongolian agricultural university.14-40